

Banding Tool

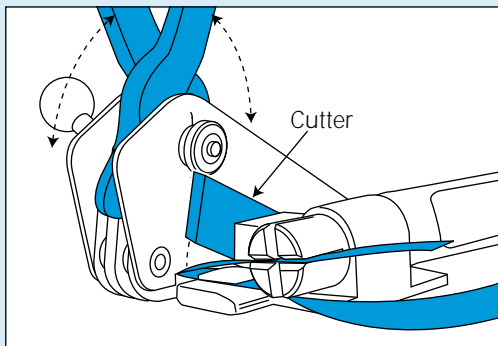
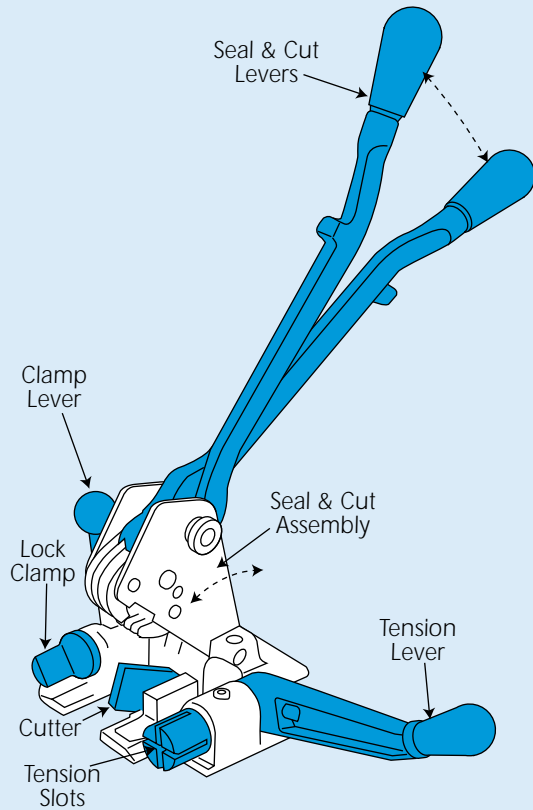

EQUIPMENT CARE

Never push the equipment beyond its design limits. If it will not do what you want with reasonable ease and speed, assume you have the wrong tool for the job. Contact your local HSS Hire Shop for advice.

Only use tape and seals supplied by HSS, any other make or type of tape or seal may not work correctly and may damage the equipment.

Keep the equipment clean - you will find this less of a chore if you clean it regularly, rather than wait until the end of the hire period.

When not in use, store the equipment somewhere clean, dry and safe from thieves and unauthorised users.

FINISHING OFF

Collect all parts together and give everything a final clean up ready for return, to your local HSS Hire Shop.



...any comments?

If you have any suggestions to enable us to improve the information within this guide please fax your comments or write to the Product Manager at the address below

Fax: 020 8687 5001

©HSS Hire Service Group Plc 2001 No. 470/01

Group Office: 25 Willow Lane, Mitcham, Surrey CR4 4TS

Web Site: <http://www.hss.co.uk>

HSS Hire Shops

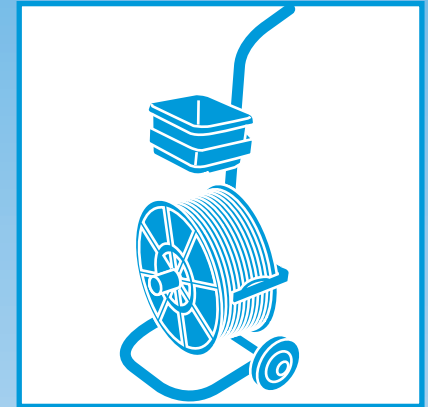

Polypropylene Strapping System

A single tool for tensioning, sealing and cutting polypropylene strapping, supplied complete with trolley.



GENERAL SAFETY

For advice on the safety and suitability of this equipment contact your local HSS Hire Shop.

There is a serious risk of personal injury if you do not follow all instructions laid down in this guide.

The hirer has a responsibility to ensure that all necessary risk assessments have been completed prior to the use of this equipment.

This equipment should only be used by an operator who has been deemed competent to do so by his/her employer.

This equipment should be used by an able bodied, competent adult who has read and understood these instructions. Anyone with either a temporary or permanent disability, should seek expert advice before using it.

Keep children, animals and bystanders away from the work area. Cord off a NO GO area using cones and either barriers or tape, available for hire from your local HSS Hire Shop.

 Never use this equipment if you are ill, feeling tired, or under the influence of alcohol or drugs.

 Wear practical, protective clothing, gloves and footwear. Avoid loose garments and jewellery that could get in the way of the work, tie back long hair.

Ensure the work area is well lit and ventilated, if in doubt, ask about lighting and ventilation equipment at your local HSS Hire Shop.

Make sure that anyone in the immediate work area is warned of what you are doing.

Check the condition of the equipment before use. If it shows signs of damage or excessive wear, return it to your local HSS Hire Shop.

GETTING STARTED

Load the trolley with a new drum of polypropylene tape. Pull out the retaining pin and remove any remaining drum.

Slide the new drum onto the trolley's spindle so that the tape is fed clockwise from the trolley. Re-insert the retaining pin then finally, feed the end of the tape through the guide slot (see illustration).

Set the trolley behind the item being banded, or where a bench is in use, position it on the opposite side of the bench from the operator.

Before starting, make sure that you have an adequate supply of seals, available on sale or return from your local HSS Hire Shop.

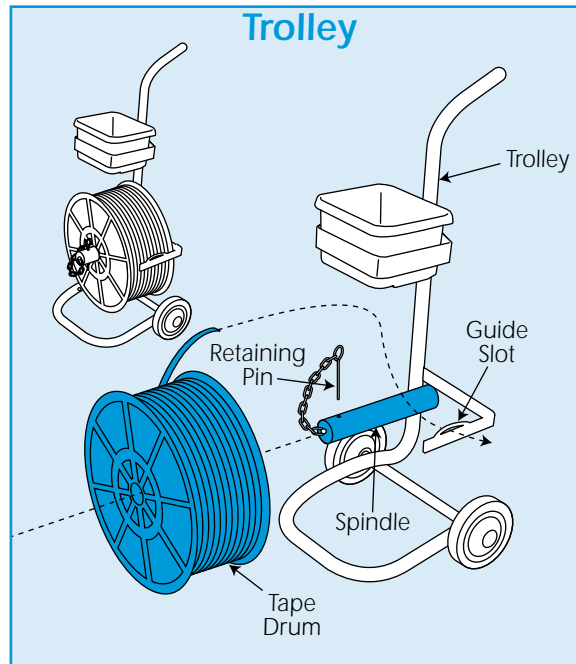

BASIC TECHNIQUES

Pull out a length of polypropylene tape and feed it firstly under the item (towards you) then over the item (away from you).

Place the banding tool on top of the item with the tension lever pointing towards you. Move the seal and cut assembly to the right to clear it from the tape.

Open the tape end lock clamp by moving the clamp lever back. Insert the tape end under the guide plate and under the lock clamp, then secure in position by moving the clamp lever forward.

Take hold of the tape between the item and the trolley, then keeping reasonable tension, pull the tape up and back to position it over the lock clamp and through the cutter, then insert it through the tensioner slots.

Pull the tape tight through the slots then tension the tape by moving the tension lever up and down, tension is increased on each upward stroke.

Once the tape is at the required tension, the tape can be secured with a clench seal.

Position a seal over the two layers of tape with the open face of the seal towards the item.

Open the sealer's jaws and place them over the seal (see illustration).

To complete the seal, draw the seal and cut levers together as far as they will go.

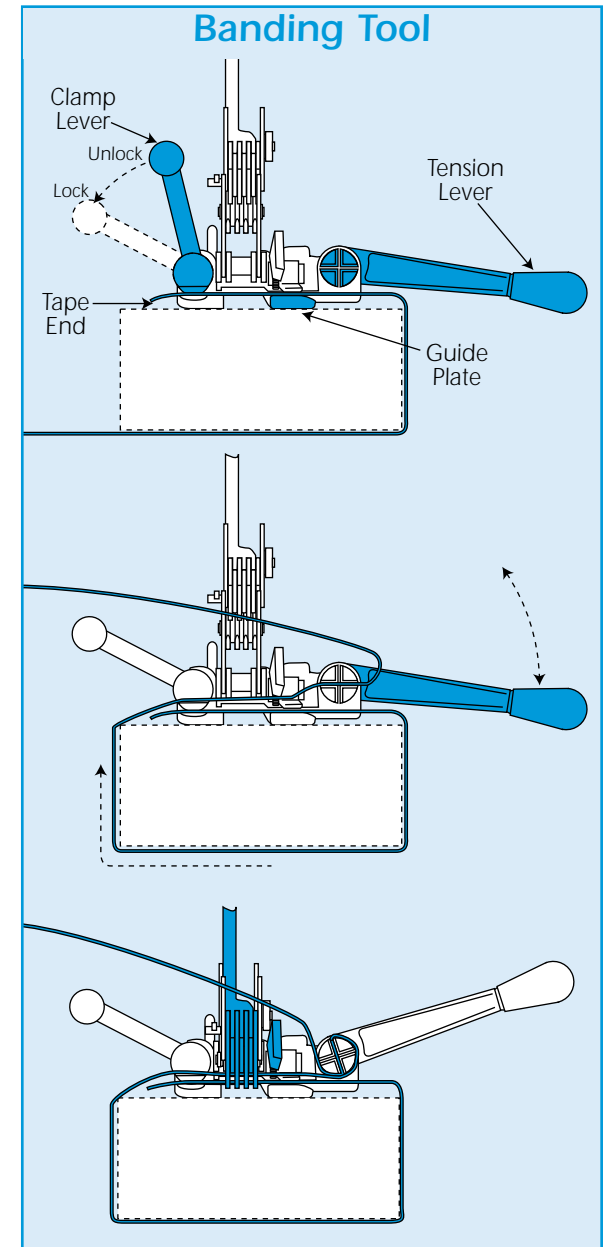

Once the seal is complete the tape end will be automatically cut, once complete, open the jaws and move the seal and cut assembly to the right to clear it from the tape.

All that remains is to release the clamp lever, remove the new end of the tape from the tensioner slots and slide the binding tool clear of the item ready for the next job.