

To scarify, simply move the machine forwards, keeping your feet clear of its body and tines.

**Work in a straight line**, tackling the lawn in a series of overlapping strips.

**For best results, start with the tines set to a light penetration** then repeat several times if necessary, gradually lowering the tines at each pass until satisfied.

**Watch your footing**, especially on wet and/or sloping ground. Work across the face rather than up and down the slope.

**If the tines should strike a stone or something similar, raise the tines, Switch OFF the engine at once and inspect for damage.** If in doubt, contact your local HSS Hire Shop for advice.

**Empty the collection box at frequent intervals** - remembering to switch OFF the engine first. Simply unhook it, empty it out, then re-fit it.

**In an emergency, simply release the dead-mans handle.** The engine will automatically cut out.

## EQUIPMENT CARE

**Never push the equipment beyond its design limits.** If it will not do what you want with reasonable ease, assume you have the wrong tool for the job. Contact your local HSS Hire Shop for advice.

**Keep the engine upright at all times.** If it should turn over, cleanup any oil or fuel spillages and contact our local HSS Hire Shop for advice.

**Keep the equipment clean.** You will find it performs better if you clean it regularly rather than wait until the end of the hire period.

When not in use, **store the equipment somewhere clean, dry and safe** from thieves.

**Regularly check the fuel level and top up as necessary** using unleaded petrol.

**Regularly check the oil level** - when the engine is cold and with the machine on level ground. Withdraw the dip stick, wipe it clean and replace. Now replace it, a second time and verify that the oil level is between the Min and Max lines. **Top up as necessary.**

## FINISHING OFF

**Set the throttle control to the STOP position, then wait for the engine to die** and for moving parts to stop.

**Empty the grass collection box and give the unit a final clean ready for return** to your local HSS Hire Shop.



## ...any comments?

If you have any suggestions to enable us to improve the information within this guide please fax your comments or write to the Product Manager at the address below

**Fax: 0181-687 5001**

©HSS Hire Service Group Plc 1998 No. 554/01

Group Office: 25 Willow Lane, Mitcham, Surrey CR4 4TS

Web Site: <http://www.hss.co.uk>

## Operating & Safety Guide 554

# HSS Hire Shops

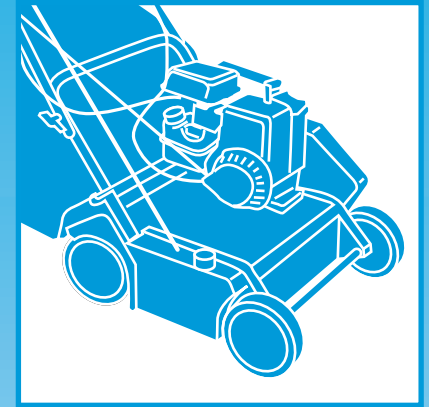

## Lawn Scarifiers

**For dethatching and scarifying large lawn areas. A must for maintenance of fine lawns and bowling greens.**

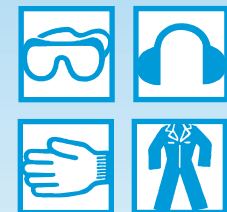

Code 62316

## GENERAL SAFETY

For advice on the safety and suitability of this equipment contact your local HSS Hire Shop.

There is a serious risk of personal injury if you do not follow all instructions laid down in this guide.

This equipment should be used by an able bodied, competent adult who has read and understood these instructions. Anyone with either a temporary or permanent disability, should seek expert advice before using it.

Keep children, animals and bystanders away from the work area.

 Never use this equipment if you are ill, feeling tired, or under the influence of alcohol or drugs.

This equipment should only be used by a competent person who has read and understood these instructions.

There is a serious risk of personal injury if you do not follow all instructions laid down in this guide.

 This equipment generates potentially harmful noise levels. To comply with health and safety at work regulations, ear defenders must be worn by everyone in the vicinity.

 Wear practical, protective clothing, gloves and footwear. Avoid loose garments and jewellery that could catch in moving parts, tie back long hair.

Ensure the work area is well lit and ventilated.

## Exhaust Danger

**NEVER** operate petrol engines indoors or in a confined space.

The exhaust contains gases that can Kill.

Always switch OFF the equipment before moving it to another site or servicing it. Allow petrol engines to cool.

Engines, especially the exhausts, get very hot so switch OFF and allow to cool before touching them.

Keep flammable materials well away from the engine and exhaust.

Never tamper with safety devices, they are there for your protection.

Scarifier tines can cause serious injury. Always keep feet and hands well away from the tines while the machine is switched ON, taking special care when starting.

Always switch OFF the machine and wait for the moving parts to stop before cleaning, moving or inspecting it.

Check the equipment before use. If it shows signs of damage or excessive wear, return it to your local HSS Hire Shop.

## Fuel Safety

**NEVER** refuel while the engine is hot or running. Never smoke or allow naked lights into the area while refuelling.

Never inhale fuel vapour.

**ALWAYS** mop up spillages as quickly as possible, and change your clothes if you get fuel on yourself.

**ALWAYS** store fuel in a purpose-made sealed container, in a cool, safe place well away from the work area.

Make sure you know how to switch this machine OFF before you switch it ON in case you get into difficulty.

## GETTING STARTED

Clear the area to be scarified of everything that could get in the machines way – sticks, stones, washing lines & garden furniture etc.

Any long grass should be cut and cleared, as this machine is designed to work over low grass.

Place the unit on firm level ground ready for starting, away from structures which could be damaged by flying debris, a green house for example.

Swing the handle to working height and secure the two thumb screws.

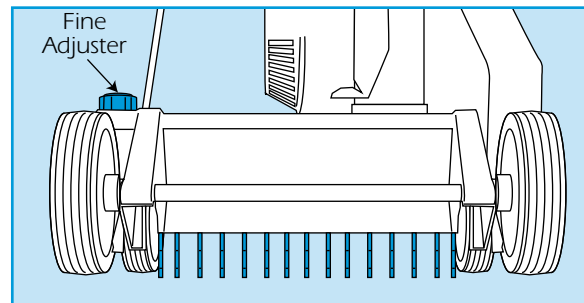

Set the tines to match the soil level. To do this, firstly ensure the tine control lever is in the lowered position (pushed forward) then turn the fine adjuster until the tines just touch the soil.

Finally move the loose pointer in the centre of the adjuster to point at the arrow on the chassis and return the control lever to the raised position.

Now set the tines to the required depth by turning the fine adjuster anti-clockwise. One full (360 degrees) turn will lower the tines by 1.5mm. Remember that the tines will not touch the surface until lowered by the tine control lever.

Where applicable, lift the safety flap at the rear of the machine and fit the collection box, making sure it is securely hooked in place.

## SABO

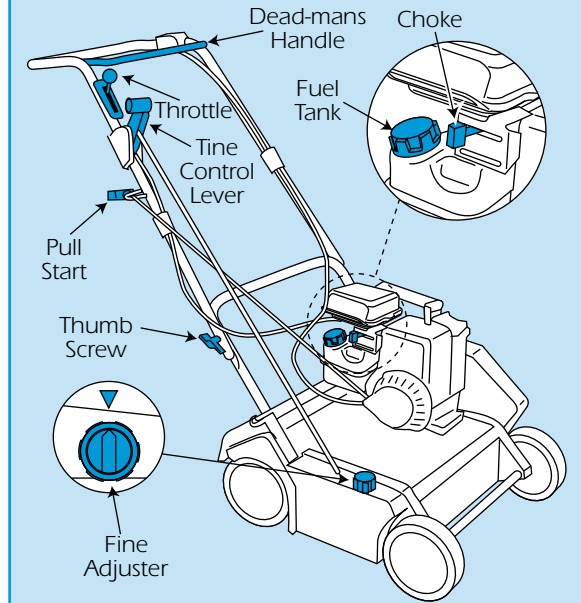

Set the throttle lever to fast then set the choke fully on if starting from cold, half on if the engine has already warmed up.

Any dead-man's handle fitted should now be held against the main handlebar -or the engine won't start and will cut out as soon as the handle is released.

A few pulls on the starter cord should now start the engine. Once started, let the engine warm up for a few minutes before opening the choke and setting the throttle to operating speed.

## BASIC TECHNIQUES

With the machine set up on the lawn set the throttle to fast and lower the tines.

## Fitting the Bag

