

Watch your footing, especially on wet and/or sloping ground. Work across the face rather than up and down the slope.

This machine can be used with a remote vacuum hose and tube, fitted to the top of the front scoop. There is a round cover clipped to the top of the scoop which is removed by twisting a screwdriver under its edge. The hose then simply clips into position.

Fitting the Remote Vacuum Hose

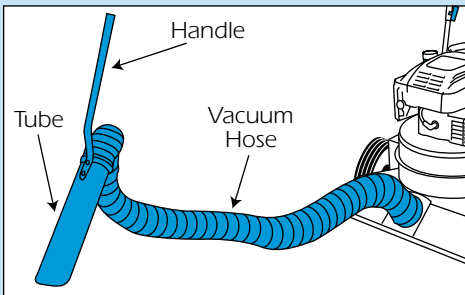
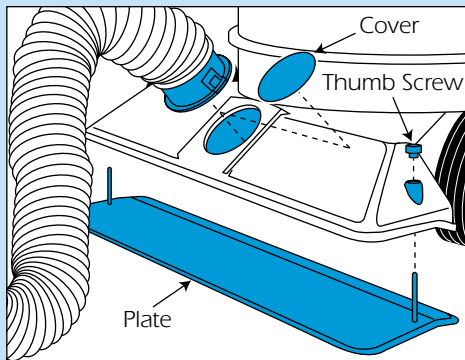

To ensure the vacuum works properly, **block off the scoop with the plate provided** and secure with the two thumbscrews, (see illustration).

If the machine should pick up a stone or something similar, stop the engine at once. Switch OFF **and inspect for damage.** If in doubt, contact your local HSS Hire Shop for advice.

Empty the collection bag at frequent intervals - remembering to switch OFF the engine first. Simply unhook it, empty it out, then re-fit it.

Finally, **set the throttle control in the STOP position, then wait for the engine to die** and for moving parts to stop.

In an emergency, however, simply **release the Operators Presence Lever.** The engine will automatically cut out.

EQUIPMENT CARE

Never push the equipment beyond its design limits. If it will not do what you want with reasonable ease, assume you have the wrong machine for the job. Contact your local HSS Hire Shop for advice.

Keep the engine upright at all times. If it should turn over, clean up any oil or fuel spillages and contact your local HSS Hire Shop for advice.

Keep the equipment clean. You will find it performs better if you clean it regularly rather than wait until the end of the hire period.

When not in use, **store the equipment somewhere clean, dry and safe** from thieves.

Regularly check the fuel level and top up as necessary using unleaded petrol.

Regularly check the oil level - when the engine is cold and with the machine on level ground. Withdraw the dip stick, wipe it clean then replace it a second time and verify that the oil level is between the Min and Max lines. **Top up as necessary.**

FINISHING OFF

Switch the engine OFF, empty the collection bag and give the unit a final clean ready for return to your local HSS Hire Shop.



...any comments?

If you have any suggestions to enable us to improve the information within this guide please fax your comments or write to the Product Manager at the address below

Fax: 0181-687 5001

©HSS Hire Service Group Plc 1998 No. 567/01
Group Office: 25 Willow Lane, Mitcham, Surrey CR4 4TS

Web Site: <http://www.hss.co.uk>

Operating & Safety Guide 567

HSS Hire Shops



Litter Vacuum

For clearing litter, leaves and rubbish from paths, drives, car-parks and other open areas.





Code 58725

GENERAL SAFETY

For advice on the safety and suitability of this equipment **contact your local HSS Hire Shop.**

This equipment should be used by an able bodied, competent adult who has read and understood these instructions. Anyone with either a temporary or permanent disability, should seek expert advice before using it.

Keep children, animals and bystanders away from the work area.

  **Never use this equipment if you are ill, feeling tired, or under the influence of alcohol or drugs.**

 **This equipment generates potentially harmful noise levels.** To comply with health and safety at work regulations, **ear defenders must be worn** by everyone in the vicinity.

 **Wear practical, protective clothing, gloves and footwear.** Avoid loose garments and jewellery that could catch in moving parts, tie back long hair.

Ensure the work area is well lit and ventilated.

Exhaust Danger

NEVER operate petrol engines indoors or in a confined space.

The exhaust contains gases that can Kill.

Always switch OFF the equipment before moving it to another site or servicing it.

Engines, especially the exhausts, get very hot so switch OFF and **allow to cool before touching them.**

Keep flammable materials well away from engine and exhaust.

Never tamper with safety devices, they are there for your protection.

NEVER operate the machine without the collection bag fitted, materials vacuumed exit the unit at high speeds.

Do not vacuum any burning or smouldering materials such as cigarettes.

Always switch OFF the machine and wait for the moving parts to stop before cleaning, moving or inspecting it.

Check the equipment before use. If it shows signs of damage or excessive wear, return it to your local HSS Hire Shop.

Fuel Safety

NEVER refuel while the engine is hot or running.
Never smoke or allow naked lights into the area while refuelling.

Never inhale fuel vapour.

ALWAYS mop up spillages as quickly as possible, and change your clothes if you get fuel on yourself.

ALWAYS store fuel in a purpose-made sealed container, in a cool, safe place well away from the work area.

Make sure you know how to switch this machine OFF before you switch it ON in case you get into difficulty.

GETTING STARTED

Clear the area to be vacuumed of everything that could get in the machines way – sticks, stones, garden furniture etc.

Place the unit on firm level ground ready for starting, then **fill the fuel tank** with unleaded petrol.

Setting the Front Wheels

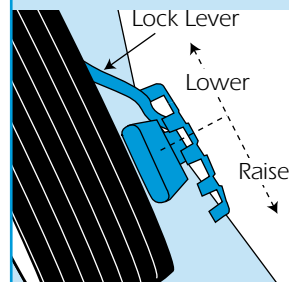

Set the front wheels to match the terrain i.e. if totally flat the front scoop can be lowered fully, if uneven, the front scoop should be raised enough to clear any undulations.

To do this, simply pull out the adjuster lock lever, move the wheel up or down and re-lock to the nearest castellation. Do **ensure that both left and right wheel are set to the same height.**

The collection bag should already be fitted, if not, slide the straps on the top of the bag, over the rear handle assembly.

Clip the front top of the bag to the two pins on the handle assembly (see illustration) then finally slide the bags opening over the units outlet and secure with the strap provided.

Set the engines control lever to the START position, open the fuel tap and if the engine is cold, push the prime bulb 3 times.

Any Operators Presence Lever fitted should now be held against the main handlebar -or the engine

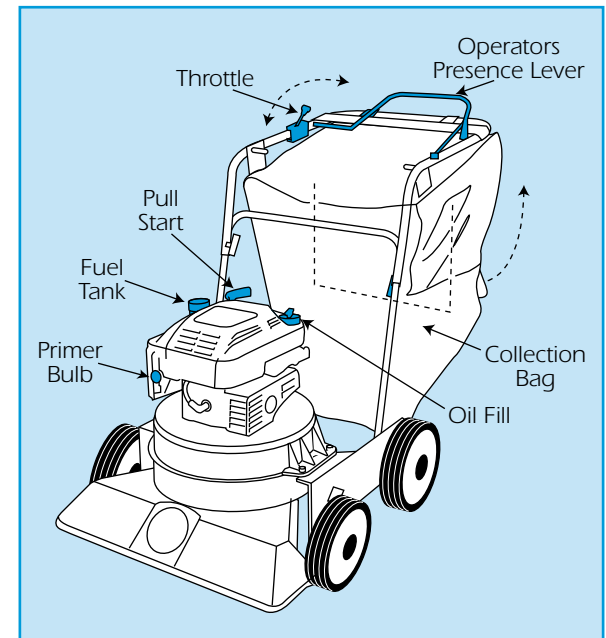

won't start and will cut out as soon as the handle is released.

Two or three brisk pulls on the starter cord, should now start the engine.

Once the engine has warmed up, reset the throttle to idling (tortoise) speed.

BASIC TECHNIQUES

Set the throttle to fast (rabbit) then, to begin vacuuming, **simply move the machine forwards.**

Work in a straight line, tackling the area in a series of overlapping strips.

Fitting the Collection Bag

