

HSS Hire

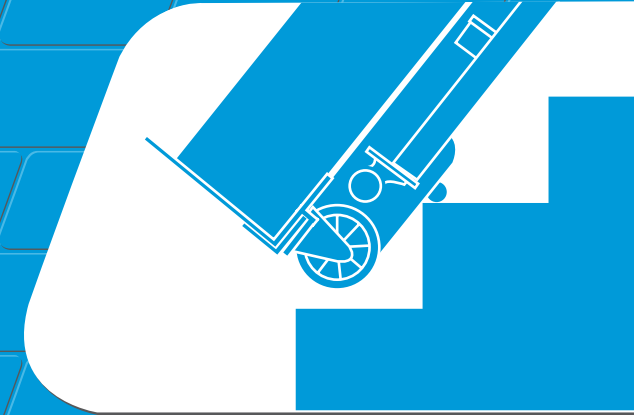

Powered Stair Climber

A battery powered stair climbing trolley



Code 70492

When loaded and ready to climb, the rear support must be folded back and locked in position, simply reverse the previous instruction.

Take the unit to the load and set the unit upright. Slide the base plate under the load and secure to the stair climber with the straps.

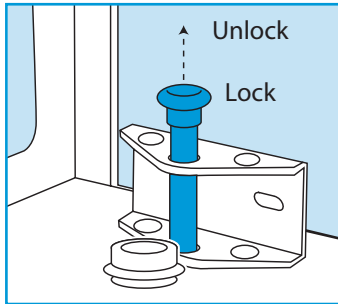

Take the unit to the load and set the unit upright.

Slide the base plate under the load and secure to the stair climber with the straps.

To secure the load use the built in retainer straps fitted to the unit. Slide the male clip to the end of its captive strap, pull the female end around the load and insert the male until securely fastened (this is the same action as a car safety seat belt). The movable female strap should now be locked, to do this simply push in the retaining pin. Finally take up any slack by pulling the end of the male strap, until tight.

Repeat this operation on both sets of straps. To release the straps, simply push the red release button in the centre of the female fitting. Once released pull the lock pin clear and allow the female strap to recoil in its holder.

BASIC TECHNIQUES

When loading and unloading, make sure that the weight is evenly distributed or the load may overbalance. Place the load as far back on the bed as possible and centre it across the width.

Once securely fitted, wheel the unit to the base of the stair, then with help, fold the rear support assembly back and lock in position.

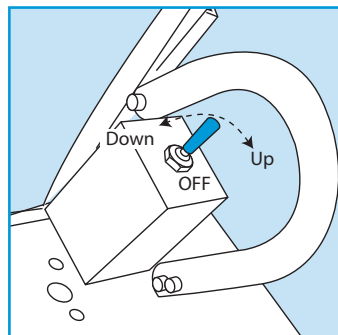

Walk backward up the stair until the rear of the unit seats against the top of the first step. Position your right thumb against the ON OFF / Direction switch and push to the right. Be ready for the balance of the load to alter as the unit begins to rise up the step.

You only need to control the balance of the load as it rises up the stair, the unit will do all the heavy work.

Once at the top, release the direction control and if appropriate, deploy the rear support leg again.

To take a load down a flight of stairs start at the edge of the top step, move the control to the left and again keep the balance until the unit reaches the ground.

If the unit stops mid stair due to a discharged battery, you can lower the unit back down the stairs by pushing the control switch to the left. To recharge the battery follow the instructions in 'ELECTRICAL SAFETY'

EQUIPMENT CARE

Never try to push the equipment beyond its design limits. If it will not do what you want with reasonable speed and ease, assume it is the wrong equipment for the job. Ask at your local HSS Hire for advice.

Keep the equipment clean. You will find this less of a chore if you clean up regularly rather than waiting until the end of the hire period.

Never wheel this type of equipment over rough ground. It damages the equipment and could prove to be extremely dangerous. When not in use, store the equipment somewhere clean, dry and safe from thieves.

FINISHING OFF

Release the load retaining straps, then slide the unit from under the load. Give the unit a final clean ready for return to your local HSS Hire.



... have you been trained

The law requires that personnel using work equipment have received adequate training and must be competent when using the equipment within the workplace.

Training is available at HSS Training Solutions
0845 766 7799

...any comments?

If you have any suggestions to enable us to improve the information within this guide please e-mail your comments or write to the Safety Guide Manager at the address below
e-mail: safety@hss.com

©HSS Hire Service Group Ltd 2010 No. 619/02

Group Office: 25 Willow Lane, Mitcham, Surrey CR4 4TS

Web Site: <http://www.hss.com>

GENERAL SAFETY

For advice on the safety and suitability of this equipment contact your local HSS Hire.

There is a serious risk of personal injury if you do not follow all instructions laid down in this guide.

This equipment is designed to be used by an able bodied, competent adult who has read and understood these instructions. Anyone with either a temporary or permanent disability should seek expert advice before using it.

Keep children, animals and bystanders away from the work area. Cordon off a NO GO area using cones and either barriers or tape, available for hire from your local HSS Hire.

 Never use this equipment if you are ill, feeling tired, or under the influence of alcohol or drugs.

 Wear practical protective clothing, gloves and footwear. Avoid loose garment and jewellery that could catch in moving parts, tie back long hair

 Ensure the load is balanced and stable and that personnel stand clear of the raised load.

Make sure you know how to operate this equipment safely and are aware of its limitations before you use it.

It is both the hirers and the operators responsibility to perform a risk assessment before using this equipment. You are also responsible for the safety of any one in the work area.

Make sure that anyone in the immediate work area is warned of what you are doing. Never allow anyone under a raised load or in a position where they are at risk if the load shifts.

This equipment MUST NOT be used to carry personnel or loose loads.

Never exceed the Stairclimber's safe working load of 300Kg.

Do not use this equipment to raise items which are wider than the fork area. Ensure the load has a flat base or if not, is attached to a suitable pallet.

Never use the Stairclimber unless the restraining straps are evenly and securely fitted around the load.

NEVER allow anyone on the stairway below the unit when in use.

Always switch OFF and unplug the charger when not in use.

Check the condition of the equipment before use. If it shows signs of damage or excessive wear, return it to your local HSS Hire.

ELECTRICAL SAFETY

The battery charger is designed to plug straight into a standard 240V 13A power socket, however, power must not be supplied from a generator.

Using the charger in very damp or wet conditions can be dangerous.

 To reduce the risk of electric shock, use a suitable RCD (Residual Current-Operated Device) available from your local HSS Hire, or power 240V (not 110V) equipment from a power circuit with a built-in RCD.

If the tool fails, or if the charger's power supply cable or plug gets damaged, return it. Never try to repair it yourself.

If an extension lead is used for the charger it should be fully unwound and loosely coiled, away from the equipment. Never run leads through water, over sharp edges or where they could trip someone.



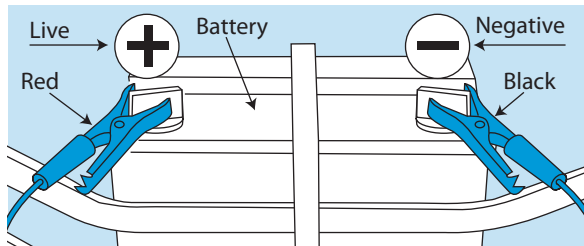

Never carry or pull the charger by its power supply cable.

To recharge, pull the covers clear of both battery terminals, attach the clip connected to the red wire to the live terminal on the battery, then connect the black to the negative.



Then plug the charger into a suitable power supply and switch the power ON, recharging is fully automatic.

The charger will recharge the battery in 3 stages as indicated by the lamps on the front of the charger.

	● Lamp 1	Power ON
	● Lamp 2	Stage 1 Charging
	● Lamp 3	Stage 2 Charging
	● Lamp 4	Stage 3 Charging

Once fully charged, switch OFF and unplug the unit from its power supply. Disconnect the clips from both battery terminals and replace the terminal covers.

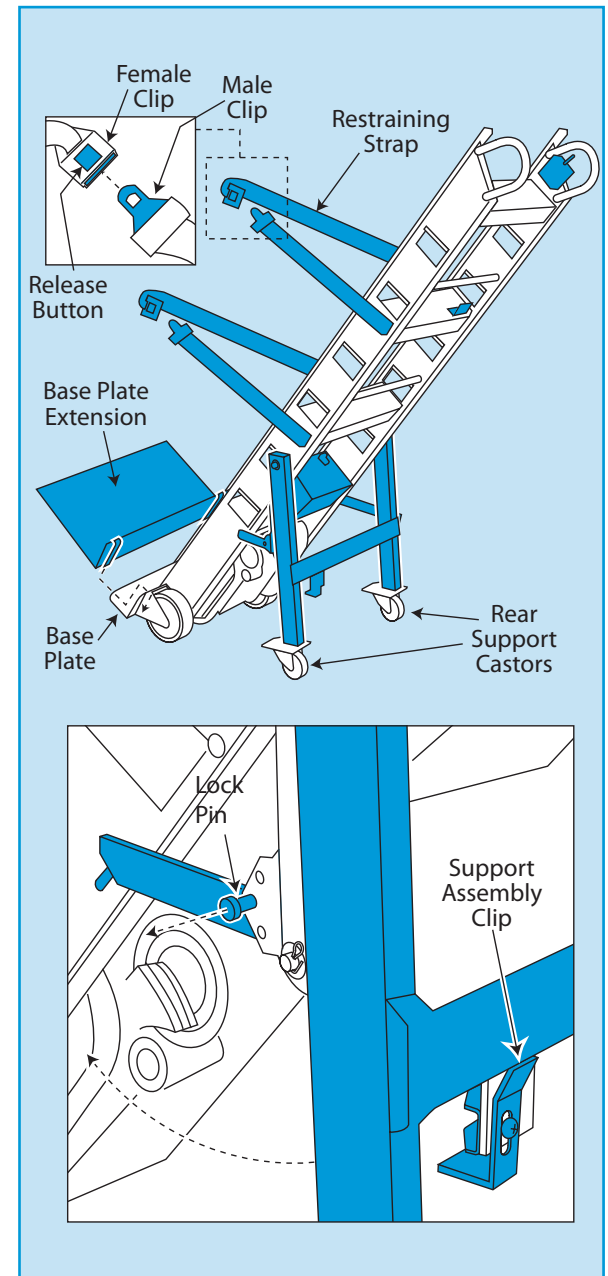

GETTING STARTED

Make sure the battery is FULLY charged before starting the work. Set the unit upon its rear support castors, to do this unclip the rear support assembly and swing fully out. Lock the assembly by sliding the lock pin across (see illustration)