

The units can be supported using scaffold tube or steel trestles. Make sure that the sides are level and that the unit does not rock. The unit must be correctly supported.

Once positioned, connect the link cable from the control box to the socket nearest to the direction of travel.

If only one unit is being used, plug the terminator plug into the remaining socket.

If however, additional units are to be used, connect a link cable from the remaining socket to the next units socket nearest its direction of travel (see illustration).

Each additional unit should be connected in this way with the terminator plug being fitted to the remaining socket on the last unit.

Connect the power supply cable to the control box and switch the supply ON.

ATTACHMENTS

Conveyor Connector...

This device connects two units together allowing them to 'bridge' an area. You can connect up to three conveyors using this method.

The lower conveyor's belt must be travelling away from the connector and the upper, toward it.

Set the lower conveyor on the ground and place the left side panel on to the conveyor left top edge, (see illustration). The side panel's location holes should align with the lugs on the conveyor.

Insert the end bar of the flap into the flap hole of the side panel. Holding the flap, position the right side panel on to the conveyor whilst inserting the other end of the flap into its respective hole.

With all three components positioned, insert one retaining bar through the right and left side panels and lower conveyor connection tube.

To lock the retaining bar in place, thread the chain through the end hole (see illustration).

Align the upper conveyor over the two side panels and secure in place by passing the remaining retaining bar through the two panels and the upper conveyor connection tube.

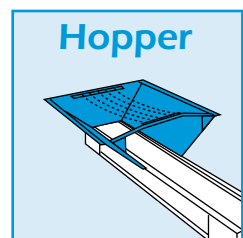

Hopper

Hopper...

Used to help guide debris neatly onto the belt area, this item simply locates on the loading end of the unit. Ideal if using a mini digger for loading or when the load is being transferred from another unit.

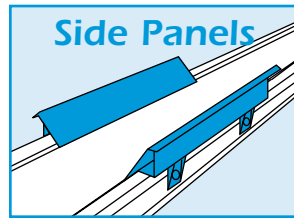

Side Panels

Side Panels...

Used to minimise side spillage, they too simply clip onto the unit. Should be used where the load is loose debris or in situations where the unit is elevated.

BASIC TECHNIQUES

To run the unit/s, press the green button, to stop, press the red button.

Press the green button, the unit/s will start slowly at first but rapidly increase to normal running speed.

Leave the unit/s to warm up for about 10 minutes, and check that everything is set up correctly.

If the unit/s do not run, press the red stop button and contact your local HSS Lift & Shift Depot for advice.

In an emergency either press the red button on the control box or disconnect any of the link cables or supply leads.

Do not exceed the maximum payload of 35kg at 1m spacing or 100kg evenly spread.

EQUIPMENT CARE

Never push the equipment beyond its design limits. If it will not safely do what you want with reasonable ease and speed, assume you have the wrong equipment for the job. Contact your local HSS Lift & Shift Depot for advice.

Each unit is fitted with an over heat sensor which will switch OFF the power at the control box if any unit overheats.

If this happens, leave the unit/s for approximately 15/30 minutes (longer in hot weather) to allow for cooling. The unit/s can be restarted when the green button on the control box is illuminated.

Over heating can be caused by overloading the unit/s, by insufficient power supply or voltage drop. Before restarting, check for these possible causes and take the necessary precautions to stop over heating again.

Keep the equipment clean, you will find this less of a chore if you clean it regularly, rather than wait until the end of the hire period.

When not in use, store the equipment somewhere clean, dry and safe from thieves.

FINISHING OFF

Switch the unit/s OFF and unplug from the power supply.

Disconnect and neatly coil all cables and place with the control box.

Give the unit/s a final clean, ready for return to your local HSS Lift & Shift Depot.

Operating & Safety Guide LS13

LS13/02

HSS Lift & Shift

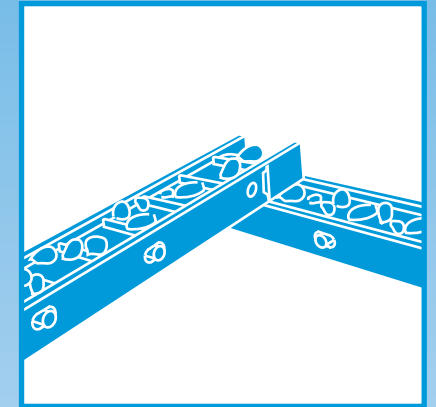

Miniveyor and Mightyveyor

A conveyor system for moving loads up, down or across an area.



...any comments?

If you have any suggestions to enable us to improve the information within this guide please fax your comments or write to the Product Manager at the address below

Fax: 020 8687 5001

©HSS Hire Service Group Plc 2002 No. LS13/02
Group Office: 25 Willow Lane, Mitcham, Surrey CR4 4TS

Web Site: <http://www.hss.com/liftandshift>

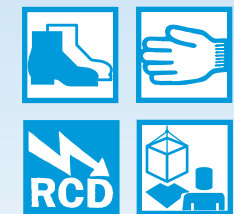

Code 71100/1/2/3/8/9/10/3/7

GENERAL SAFETY

For advice on the safety and suitability of this equipment contact your local HSS Lift & Shift Depot.

There is a serious risk of personal injury if you do not follow all instructions laid down in this guide.

The hirer has a responsibility to ensure that all necessary risk assessments have been completed prior to the use of this equipment.

This equipment should only be used by an operator who has been deemed competent to do so by his/her employer.

This equipment is designed to be used by an able bodied, competent adult who has read and understood these instructions. Anyone with either a temporary or permanent disability should seek expert advice before using it.

Keep children, animals and bystanders away from the work area. Cordon off a NO GO area using cones and either barriers or tape, available for hire from your local HSS Lift & Shift Depot.

 Never use this equipment if you are ill, feeling tired, or under the influence of alcohol or drugs.

 Wear practical, protective clothing, gloves, footwear and a protective hard hat. Avoid loose garments and jewellery that could catch in moving parts, tie back long hair.

 This equipment is heavy, never attempt to lift a section on your own, always get help.

Never switch OFF the equipment if loaded, never leave it switched ON and unattended.

Make sure the landing area is unobstructed and able to accept the load in size and weight.

Never exceed the equipment's safe working load of 100kg spread evenly over the 3-metre length of the Conveyor system.

Safety Warning

This equipment **MUST NOT** be used to carry or lift personnel.

Use this type of equipment only on structures that are able to bear its weight and its load.

If the unit has to be elevated above head height, ensure that pedestrians are restricted from entering the area below in case of falling debris.

Make sure you know how to switch this equipment OFF before you switch it ON in case you get into difficulty.

Always switch OFF and unplug the equipment before making adjustments to it.

Check the condition of the equipment before use. If it shows signs of damage or excessive wear, return it to your local HSS Lift and Shift Depot.

ELECTRICAL SAFETY

HSS Conveyor Systems must be provided with a suitable 110v generated supply, or be powered from the mains via a suitable 110v transformer.

Make sure that the generator or transformer is only used to supply the conveyor system. Running other equipment could cause a power supply problem.

A minimum continuous 3kVA supply is required for this equipment. If a generator or transformer is to be used check that its continuous rating is sufficient, if in doubt contact your local HSS Lift & Shift depot for advice.

The control box is capable of running a maximum of either five Miniveyors or three Mightyveyors, do not exceed this amount.

If the equipment fails, or if its power supply cable or plug gets damaged, return it. Never try to repair it yourself.

Keep flexes out of harm's way, and clear of moving parts.

Extension leads should be fully unwound and loosely coiled, away from the equipment. Never run them through water, over sharp edges or where they could trip someone.

Keep the equipment dry, using electrical equipment in very damp or wet conditions can be dangerous.

 To reduce the risk of electric shock, always use a suitable RCD (Residual Current-Operated Device) available from your local HSS Lift & Shift Depot.

Never carry or pull the control box by its power supply cable.

Ensure the equipment and power sockets are switched OFF before plugging into the power supply.

The control box is fitted with an NVR (No Volt Return) switch. The switch will only stay in the ON position if there is a power supply. If the power supply is interrupted, for whatever reason, the switch will move to the OFF position. This safeguards the user so that when the power is restored, the Conveyor system will not start without warning.

GETTING STARTED

Both the Mini and Mightyveyor should be set up in the same way.

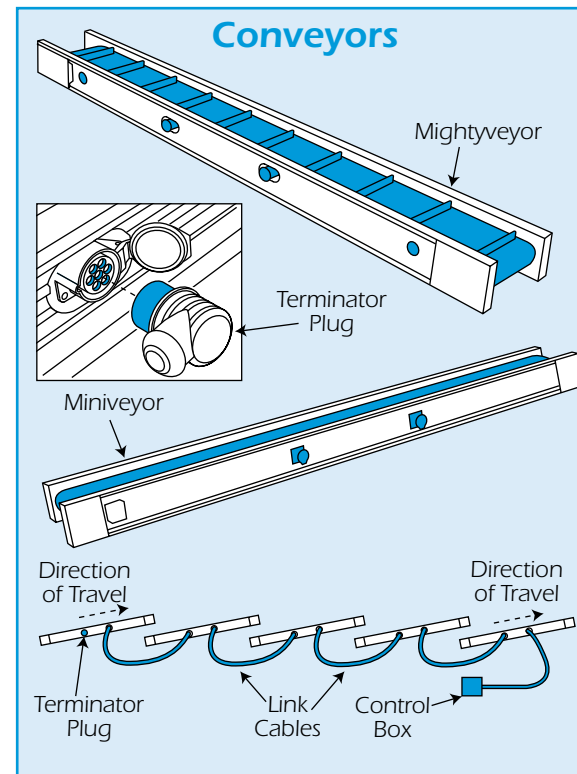

Take a unit to where it will be used and ensure the belt surface, protected by a felt side skirt is uppermost.

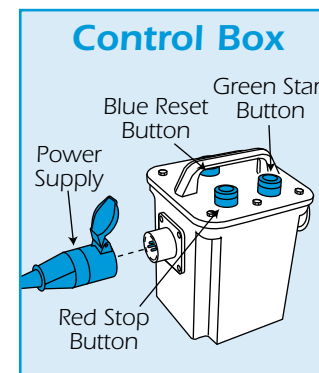

Ensure that the conveyor system is set in the correct direction of travel required. There is a main direction of travel indicating arrow on the side of the unit. The unit may be operated up hill or down hill by turning the unit round.

If additional units are to be used, make sure that the exit point of the first unit overlaps the take-up point of the next. If connecting two units together using the conveyor connector, see 'ATTACHMENTS' for instructions on how to set it up.

Do not exceed the maximum incline of 25° for the miniveyor and 35° for the mightyveyor, and where the load is loose debris, make sure that it will not roll back (simply decrease the angle).

