

BASIC TECHNIQUES

The unit is capable of 3 basic actions; Threading, Cutting and Reaming.

IF CUTTING...

The end of the pipe to be threaded must be cut square, if the end is not then use the machines built in cutter.

Open the cutting attachment by turning the end handle anti-clockwise and lower it into position around the pipe.

Align the cutting wheel at the cut off point on the pipe, but make sure that you cut no less than 1" off.

Turn the end handle clockwise to bring the cutting wheel into contact with the pipe and switch the unit ON using the foot switch.

As the cut progresses, continue turning the end handle to keep the cutting wheel in contact with the pipe until the cut is complete.

Switch OFF the unit and remove the off cut, be careful as heat is created during the cutting process, always wear protective gloves.

IF THREADING...

With the reamer and cutter moved away from the pipe, lower the die-head into position and fully open its jaws using the open / close lever.

Adjust the die-head's capacity to suit the internal diameter of the pipe being threaded. Slacken off the locking lever, move it to bring the pointer to the appropriate measurement on the scale, then re-tighten the locking lever.

Close the die-head's jaws and adjust the position of the pipe and/or die-head carriage until the leading cutter is just in contact with the end of the pipe.

Operate the foot-switch to switch ON and begin threading by slowly winding the die-head carriage forward.

Once the threading is complete, switch the machine OFF, open the die-head and wind the carriage back to leave the die-head clear of the pipe's end.

IF REAMING...

Reaming is required to remove any internal burring, un-reamed pipes impede the flow of water and create an ideal point for scale and debris to build-up.

Wind back the carriage as far as possible, raise the die head and/or the cutter then swing the reaming attachment into position.

Operate the foot-switch to switch ON and slowly wind the carriage forward to ream the end of the pipe.

Once the reaming is complete, switch OFF the machine, wind the carriage back as far as it will go and swing the reaming attachment clear of the end of the pipe.

EQUIPMENT CARE

Never push the equipment beyond its design limits. If it will not do what you want with reasonable ease, assume you have the wrong tool for the job. Ask at your local HSS Hire Shop for advice.

Keep the equipment clean. You will find this less of a chore if you clean up regularly, rather than wait until the end of the hire period.

When not in use, store the equipment somewhere clean, dry, and safe from thieves.

Watch the oil level, if the amount of oil reaching the die heads tails off, top up the sump as necessary.

Use only die sets supplied by HSS Hire Shops. Anything else may damage the equipment and your pipe.

FINISHING OFF

Switch OFF and unplug the machine.

Empty the sump by unscrewing the drain plug at the front. Allow the oil to drain into a suitable container ready for disposal.

Clean out the sump and filter cage to remove any swarf. Take care as swarf can be very sharp, so wear protective gloves.

If appropriate, remove the units legs by slackening off the Allen screws and pulling them from their sockets.

Give the machine a thorough clean and neatly coil its flex ready for return to your local HSS Hire Shop.



...any comments?

If you have any suggestions to enable us to improve the information within this guide please fax your comments or write to the Product Manager at the address below

Fax: 0181-687 5001

©HSS Hire Service Group Plc 1998 No. 754/01

Group Office: 25 Willow Lane, Mitcham, Surrey CR4 4TS

Web Site: <http://www.hss.co.uk>

Operating & Safety Guide 754

HSS Hire Shops

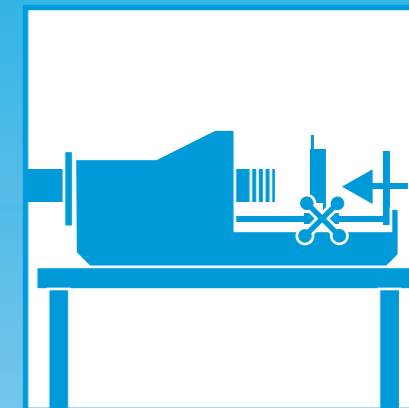

2" & 3" PIPE THREADERS

A powerful, pipe threader capable of working on pipes from 1/2" up to 3".



Code 68431/68435

GENERAL SAFETY

For advice on the safety and suitability of this equipment contact your local HSS Hire Shop.

There is a serious risk of personal injury if you do not follow all instructions laid down in this guide.

This equipment should be used by an able bodied, competent adult who has read and understood these instructions. Anyone with either a temporary or permanent disability, should seek expert advice before using it.

Keep children, animals and bystanders away from the work area.

 Never use this equipment if you are ill, feeling tired, or under the influence of alcohol or drugs.

 Safety Goggles MUST be worn by everyone in the work area.

 Wear practical, protective clothing, gloves and footwear. Avoid loose garments and jewellery that could catch in moving parts, tie back long hair.

 This machine is heavy, never attempt to lift a pipe threader on your own, always get help.

Ensure the work area is well lit and ventilated.

Do not work near flammable gases or liquids, petrol or paint thinner fumes for example. Keep combustible materials at a safe distance – at least 5m.

Make sure you know how to switch this machine OFF before you switch it ON in case you get into difficulty.

Always switch OFF and unplug the machine before making adjustments to it and when not in use.

Having switched OFF, always wait for the chuck to come to rest before removing or replacing any pipe work or accessory.

Never carry, lift or pull the equipment by its power supply cable.

Check the condition of the equipment before use. If it shows signs of damage or excessive wear, return it to your local HSS Hire Shop.

Use barriers to create a NO-GO area at the rear of the threader, to stop people accidentally walking into the tail end of the pipe.

COSHH Information sheets are available from your local HSS Hire Shop.

ELECTRICAL SAFETY

HSS 2" & 3" Pipe Threaders require a 110V supply and must be provided with a suitable 110v generated supply, or powered from the mains via a suitable 110v transformer.

If the equipment fails, or if its flex or plug becomes damaged, return it. Never try to repair it yourself.

Keep flexes out of harm's way, and clear of the work area.

Extension leads should be fully unwound and loosely coiled, away from the equipment. Never run them through water, over sharp edges or where they could trip someone.

Keep the equipment dry, using electrical equipment in very damp or wet conditions can be dangerous.

 To reduce the risk of electric shock, use a suitable RCD (Residual Current-Operated Device) available from your local HSS Hire Shop.

Ensure the Pipe Threader and power socket are switched OFF before plugging into the power supply.

GETTING STARTED

With the help of 1 or 2 able bodied people, place the unit onto a suitable work top. Alternatively, fit the unit with its 4 legs, securing them in place with the Allen key provided.

Remove the sump cover and fill the catch tray with suitable cutting oil (available from your local HSS Hire Shop), and replace the cover.

Insert the pipe into the unit from the rear, then tighten both the front and rear scroll vices. The vices should be 'knocked tight' using the heel of your hand.

This machine is supplied with a foot operated control switch, which has a safety lock-off system. Familiarise yourself with its operation before using this machine.

Under normal operation, the threader will run when light foot pressure is placed on the pad, and will STOP if the foot pressure is removed. If hard foot

Control Switch

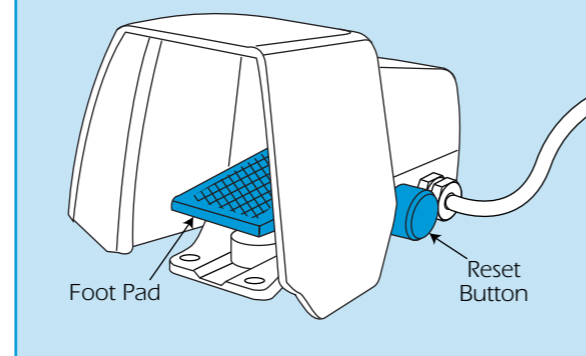

pressure is exerted on the pad, there will be a loud 'click' and the unit will STOP. The foot switch will then be isolated from the power supply.

Pipe Stand

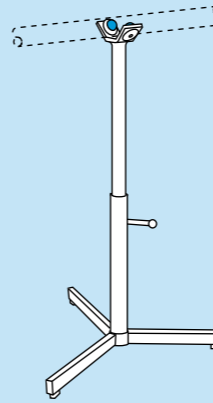

If you have finished a thread and wish to make adjustments, use this setting to ensure the unit can't be accidentally switched ON via the foot pad switch. To reset the switch simply push in the reset button on the side of the body until you hear a loud 'click'.

If working with long lengths of pipe, support the pipe on the stands provided.

CHANGING DIES

Die Head

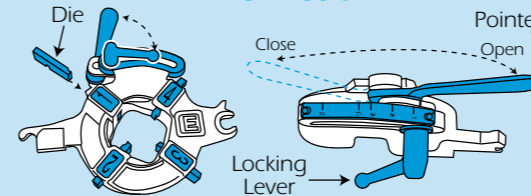

Die sets are available as follows	No. of dies in a set
1/2" - 3/4"	4
1" - 1 1/2"	4
2" - 3"	4

HSS Pipe threaders come with a full set of dies to cover pipes from 1/2" to 3". Choose the set which corresponds to the internal diameter of the pipe being worked on.

To fit new dies, fully open the die-head and adjust it to the maximum diameter by slackening off the locking lever and moving the pointer fully to the right.

Remove any previously fitted dies and return them to their box. Treat them with great care.

Insert the new dies into the die-head, ensuring the number stamped on each die matches the location number on the die-head.

Pipe Threader

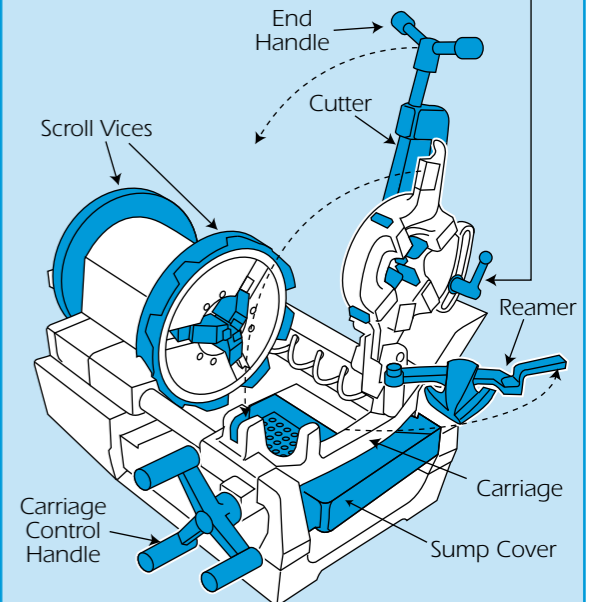
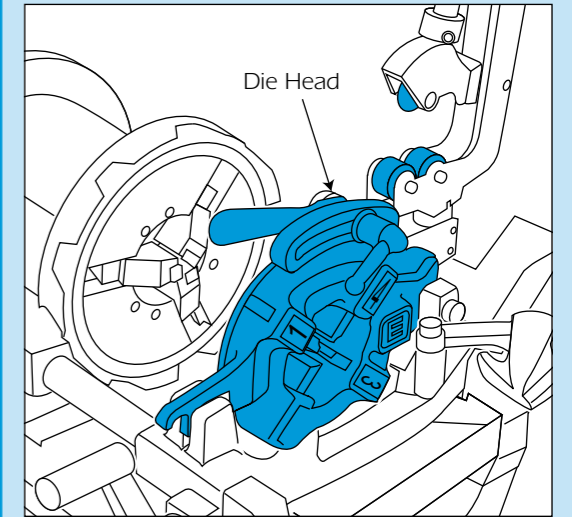

Now close the die head and lock to keep the dies in place until mounted on the threader.

Fit the die head to the carriage (see diagram).

All that remains is to plug the unit into its power supply and switch the supply ON.