

Initial Filter Cleaning

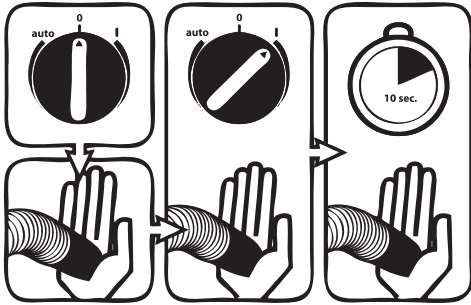

1. Switch off the Dust Extractor and attached tools
2. Close the nozzles or suction hose opening with the palm of your hand.
3. Turn the switch to position „I“ and let the cleaner operate for approx. 10 seconds with the suction hose opening closed

Emptying the waste tank

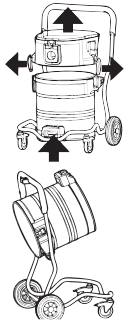

1. Remove the upper section of Dust Extractor from the waste tank.
2. Pull the lever in the handle upwards and tilt the tank.
3. Tip out the collected waste.
4. Dispose of the waste in accordance with legal regulations.

Removing the waste tank

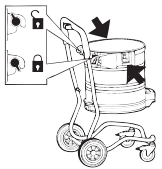

1. Open the tank locks.
2. Use the handles to lift the tank out of the frame.
4. Tip out the collected waste.
5. Place the empty tank in the frame and close the locks.
6. Dispose of the waste in accordance with legal regulations.

EQUIPMENT CARE

Never push the equipment beyond its design limits. If it will not do what you want with reasonable ease and speed, assume you have the wrong size or model for the job. Contact your local HSS Hire for advice.

Keep the equipment clean, you will find this less of a chore if you clean it regularly, rather than wait until the end of the hire period.

Check the debris bag at regular intervals and replace as necessary, following the instructions in 'OPERATING INSTRUCTIONS'. **Remember, it is your responsibility to dispose of any debris in a responsible manner.**

Handle the equipment with care. **Avoid dropping it, knocking it,** or otherwise exposing it to damage.

When not in use, store the equipment somewhere clean, dry and safe from thieves.

FINISHING OFF

Switch OFF and unplug the Dust Extractor.

Disconnect the hose. **Empty the waste tank alternatively remove the debris bag and any attachments.**

Collect all the parts together, neatly coil the flex and give the tool a final clean up ready for return, to your local HSS Hire.



... have you been trained

The law requires that personnel using dust extractors must be competent and qualified to do so. Dust Extractor training available at HSS Training Solutions
0845 766 7799

...any comments?

If you have any suggestions to enable us to improve the information within this guide please e-mail your comments or write to the Safety Guide Manager at the address below
e-mail: safety@hss.com

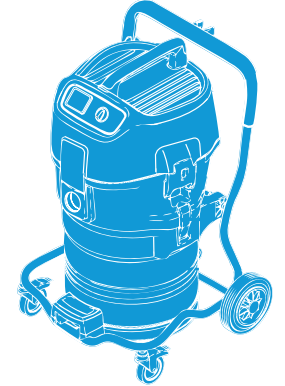

Dust Extractor

Minimises the health risk associated with working in dusty environments

The advanced filter system is automatically cleaned without interrupting your work





GENERAL SAFETY

For advice on the safety and suitability of this equipment contact your local HSS Hire.

This equipment should be used by an able bodied, competent adult who has read and understood these instructions. Anyone with either a temporary or permanent disability, should seek expert advice before using it.

Keep children, animals and bystanders away from the work area.

  Never use this equipment if you are ill, feeling tired, or under the influence of alcohol or drugs.

Ensure the work area is well lit and ventilated.

Always transport, store and operate the machine in an upright position.

Keep the unit's air vents clear of all obstructions.

This dust extractor is not suitable for picking up health-endangering dusts and hazardous materials like: glowing cigarettes, hot ashes, petrol, solvents, acids, alkalis, magnesium, aluminium dust etc.

Always switch OFF and unplug everything before attempting to empty the unit.

Before connecting the vacuum to the power, ensure it is switched off.

Never carry, lift or pull the equipment by its power supply cable or hose.

Take care not to damage the mains lead by driving over, pinching or dragging. Pull out the mains plug only directly at the plug,

Before using the dust extractor for the first time, check that it is in a good and safe condition. If it shows signs of damage or excessive wear, return it.

Do not make any technical modifications to the cleaner.

ELECTRICAL SAFETY

Most HSS dust extractors plug into a standard 240v 13Amp power socket. However, 110v models (with a round yellow plug) must be provided with a suitable 110v generated supply, or powered from the mains via a suitable 110v transformer (minimum 2kVA tool rating).

If the equipment fails, or if its power supply cable or plug becomes damaged, return it. Never try to repair it yourself. Keep cables out of harm's way, and clear of the work area.

Extension leads should be fully unwound and loosely coiled away from the equipment. Never run them through water, over sharp edges or where they could trip someone.

Using electrical equipment in very damp or wet conditions can be dangerous.

 To reduce the risk of electric shock, use a suitable RCD (Residual Current-Operated Device) available from your local HSS Hire.

Ensure the Dust Extractor and power socket are switched OFF before plugging into the power supply.

IDENTIFIER

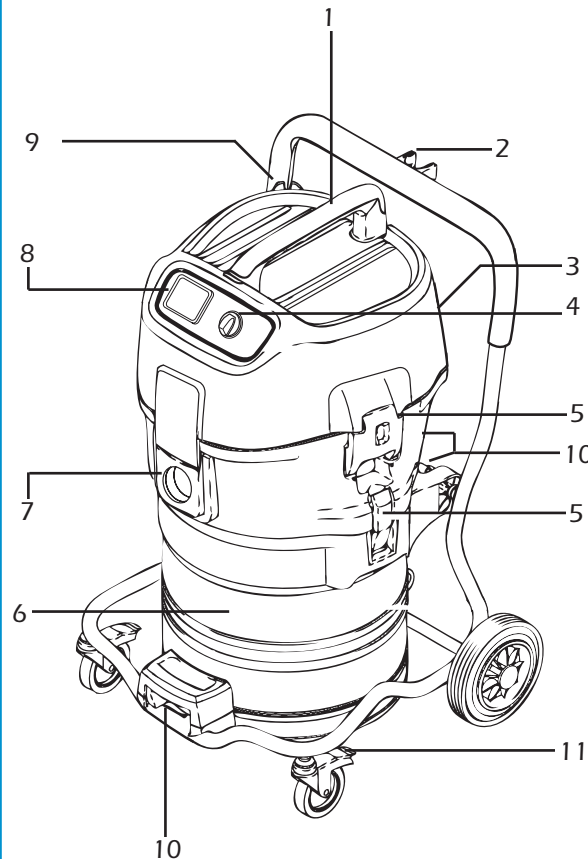

- | | |
|--|-----------------------|
| 1. Handle | 8. Appliance socket |
| 2. Suction pipe support | 9. Cable hook |
| 3. Accessory holder | 10. Tank locks |
| 4. Appliance switch with suction power control | 11. Castor with brake |
| 5. Retaining clamp | |
| 6. Waste tank | |
| 7. Inlet fitting | |

GETTING STARTED

On delivery, some of the accessories are lying in the tank and must be removed before the Dust Extractor is used for the first time. Remove the upper section of the Dust Extractor: The mains plug should not yet be inserted into a socket.

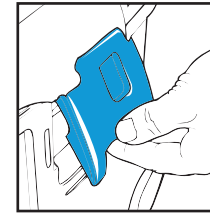

1. Open the retaining clamps and remove upper section of the Dust Extractor.
2. Take the accessories out of the dirt tank.
3. Place a filter bag into the tank as described in the instructions (printed on the filter bag).

IMPORTANT: Press the filter bag connection firmly on to the inlet fitting.

5. Fit the upper section of the cleaner (do not damage the filter bag) and close the retaining clamps.

NOTE: Ensure that the retaining clamps fit properly.

ELECTRICAL CONNECTION

The operating voltage shown on the rating plate must correspond to the voltage of the mains power supply.

Ensure that the Dust Extractor is switched off and insert the plug of the mains lead into a properly installed and fused plug socket with an earthing contact.

OPERATING INSTRUCTIONS

1. For dust extraction from a 110 volt power tool connect 110 volt electric power tool to socket making sure the wattage of the power tool does not exceed the maximum wattage shown on the socket cover.

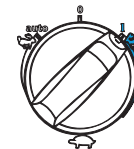

2. Turn the switch to position "I". The vacuum cleaner motor starts.

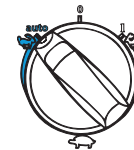

3. Turn the switch to position "auto". The vacuum cleaner motor starts when the connected power tool/pneumatic tool is switched on.

4. When the power tool is switched off, the vacuum cleaner continues to run for a short moment so that any dust in the suction hose is conveyed to the filter bag.

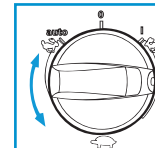

The motor speed and the suction power can be varied with the suction power control. This allows precise adjustment of the suction power for different cleaning tasks.