

Electric Mixer

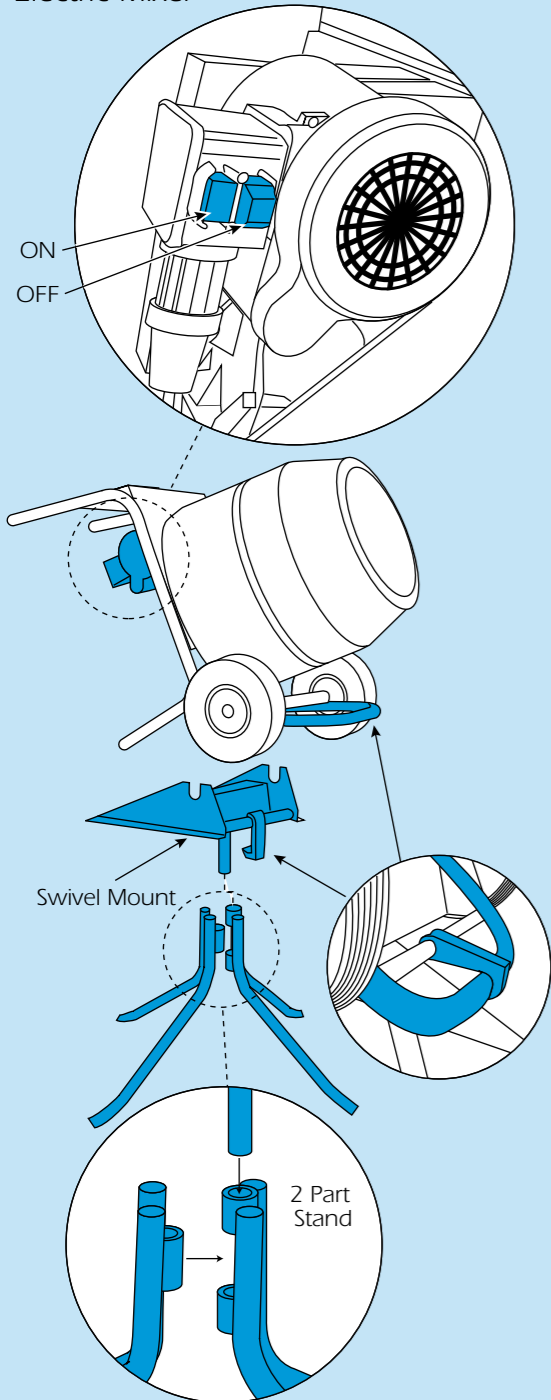

pour in the remaining water. Finally, add the sand and leave the mixer to mix away.

Once the mix is ready, **keep the drum turning while you tip the drum forward to discharge its contents.** Be careful, use both hands on the handles and be prepared for the transfer of weight as the mix moves to the end of the drum.

Once emptied, **return the mixer to the upright position. At this point it is a good idea to pour the water for the next mix, into the drum.** This will help rinse the drum as you use/lay the mixed load.

EQUIPMENT CARE

Never push the equipment beyond its design limits. If it will not do what you want with reasonable ease, assume you have the wrong tool for the job. Ask at your local HSS Hire Shop for advice.

Always switch OFF (and unplug if electric) the mixer before making any adjustments to it.

Keep the equipment clean. You will find this less of a chore if you clean up regularly, rather than wait until the end of the hire period.

When not in use, **store the equipment somewhere clean, dry and safe** from thieves.

If using a petrol mixer, regularly check the fuel level and top up as necessary with unleaded petrol.

Regularly check the oil level- when the engine is cold and the mixer is on level ground. Withdraw the dipstick, wipe it clean, then replace it, remove it a second time and verify that the oil level is between the MIN & MAX lines. **Top up as necessary.**

FINISHING OFF

Empty out any remaining mix and wash out the rotating drum with plenty of clean water- add gravel to remove stubborn residue.

When the drum is clean, **switch OFF and leave the drum in the discharge position to drain.**

If using an ELECTRIC MIXER ...
Switch the mixer OFF and disconnect the mixer from its power supply. Neatly coil the flex and all leads etc. ready for return.

If using a PETROL MIXER...
Set the throttle to minimum revs, turn OFF the ON/OFF switch and close the fuel tap.

To remove the mixer from its stand simply reverse the procedure in GETTING STARTED.

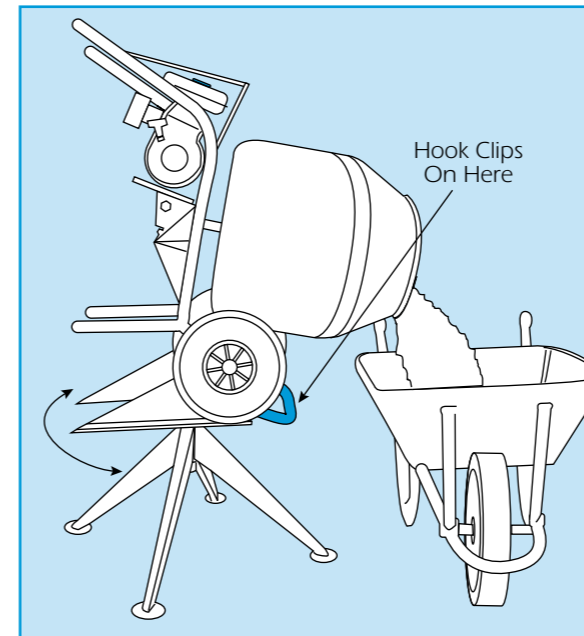

Operating & Safety Guide 647

HSS Hire Shops

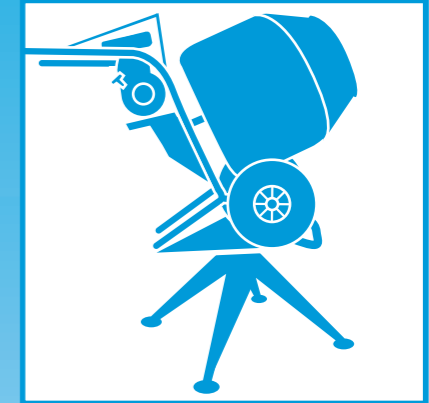

4/3 Concrete Mixers

Tip-up Mixers: 80ltr (3cuft) petrol or electric, for use by one operator on a small site.



©HSS Hire Service Group Plc 1996 No. 647/01
Group Office: 25 Willow Lane, Mitcham, Surrey CR4 4TS

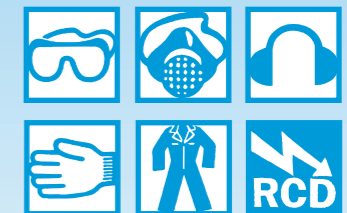

GENERAL SAFETY

For advice on the safety and suitability of this equipment contact your local HSS Hire Shop.

Keep children, animals and bystanders away from the work area.

Never use this equipment if you are ill, feeling tired, or under the influence of alcohol or drugs.

This equipment should only be used by a competent person who has read and understood these instructions.

Ensure the work area is well lit and ventilated.

Exhaust Danger



NEVER operate petrol engines indoors or in a confined space.

The exhaust contains gases that can Kill

 Safety Goggles MUST be worn by everyone in the work area.

 NOTE: Some materials (cement for instance) contain substances which, when inhaled, can be harmful to health. A suitable mask must be worn when using this equipment.

 NOTE: This equipment generates potentially harmful noise levels. To comply with health and safety at work regulations, ear defenders must be worn by everyone in the vicinity.

  Wear practical, protective clothing, gloves (for handling dry cement) and footwear. Avoid loose garments and jewellery that could catch in moving parts.

Fuel Safety

NEVER refuel while the engine is hot or running .

Never smoke or allow naked lights into the area while refuelling.

Never inhale fuel vapour.

ALWAYS mop up spillages as quickly as possible, and change your clothes if you get fuel on yourself.

ALWAYS store fuel in a purpose-made sealed container,

in a cool, safe place well away from the work area.

Always switch OFF the equipment (and unplug if electric) before moving it or servicing it. Allow petrol engines to cool.

Never leave the mixer switched ON and unattended.

Check the equipment before use. If it shows signs of damage or excessive wear, return it to your local HSS Hire Shop.

Never use the mixer without the stand.

Information on COSHH regulations is available from your local HSS Hire Shop.

ELECTRICAL SAFETY

Most HSS electric mixers plug into a standard 13amp power socket. However, 110v tools (with a round yellow plug) must be provided with a suitable 110v generated supply, or powered from the mains via a suitable 110v transformer.

Keep the flex out of harm's way and clear of moving parts. Extension leads should be fully unwound and loosely coiled, away from the equipment. Never run them through water, over sharp edges or where they could trip someone.

Using electrical equipment in very damp or wet conditions can be dangerous.

 To reduce the risk of electric shock, use a suitable RCD (Residual Current-Operated Device) available from your local HSS Hire Shop, or power 240V (Not 110V) equipment from a power circuit with a built-in RCD.

Siting an RCD

When used with a transformer an RCD will only protect the user if fitted between the transformer and the tool being used.

An RCD fitted between the power supply and the transformer only protects up to the transformer.

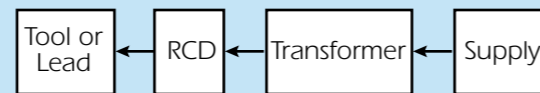

Electric mixers are fitted with an NVR (No Volt Return) switch. The switch will only stay in the ON position if there is a power supply. If the power supply is interrupted, for what ever reason, the switch will move to the OFF position. This safe guards the user so that when the power is restored, the mixer will not start without warning.

If the equipment fails, or if its plug or lead gets damaged, return it. Never attempt to repair it yourself. Never carry or pull the equipment by its flex.

GETTING STARTED

Position the stand on firm, level ground then slot the swivel-mount on to the top. On some models the stand comes in two parts and will have to be held together whilst the swivel mount is attached.

Tip the mixer forward, on to its drum and locate the stands mounting point on the mixers axle. Clip the stands hook onto the front of the mixer frame and pull the complete unit into the upright position.

If using an Electric Model...

All that remains is to plug the mixer into its power supply and switch ON.

To switch ON push the Green Button, to switch OFF simply push the Red Button. See Electrical Safety for more details of the switch.

If using a Petrol Model...

Turn ON the ON/OFF switch on the fuel tap, then set the choke- fully closed if starting from cold, half closed if the engine has warmed up.

With the throttle set to FAST, a few brisk pulls on the starter cord should now start the engine.

Once started, let the engine warm up for a few minutes before opening the choke and resetting the throttle to operating speed.

MIX 'N' MATHS

To work out how many litres of concrete you need, simply multiply the length of the area to be covered (in metres) by the width (also in metres) then multiply the result by the desired thickness (in millimetres).

Dividing by the mixers volume (80ltr) now gives the number of loads required, while the table gives a breakdown of the ingredients needed per load, of some common mixes.

CONCRETE	MIX	CEMENT	SAND	AGGREGATE
Normal	1:2:3	18 litres	36 litres	54 litres
Foundations	1:2.5:3.5	15 litres	39 litres	54 litres
Paving	1:1.5:2.5	22 litres	33 litres	55 litres
MORTAR	MIX	CEMENT	LIME	SAND
Normal	1:1:6	12 litres	12 litres	72 litres
Strong	1:0.25:3	24 litres	6 litres	72 litres

NOTE: A normal 2 gallon bucket has a capacity of about 9 litres.

BASIC TECHNIQUE

The most important thing to remember when using the mixer is that the drum must be rotating BEFORE loading and should continue to rotate until unloaded. Never switch the mixer ON with a load.

Using a bucket, put half the water needed for the mix into the rotating drum.

Add the aggregate followed by the cement, then

Petrol Mixer

