

Always return the ladder to the closed position when not in use.

EQUIPMENT CARE

Never push the equipment beyond its design limits. If it will not do what you want with reasonable ease and speed, assume you have the wrong tool for the job. Contact your local HSS Lift & Shift Depot for advice.

Keep the equipment clean, you will find this less of a chore if you clean it regularly, rather than wait until the end of the hire period.

When not in use, **store the equipment somewhere clean, dry and safe** from thieves and unauthorised users.

FINISHING OFF

Gently **lower the load and then remove it from the forks.**

Lower the fork assembly, then **engage the hold down bar.**

Set the winch handle ready for transporting. Give the Lift a final clean up ready for return, to your local HSS Lift & Shift Depot.

LOADING ONTO A FLAT BED VEHICLE

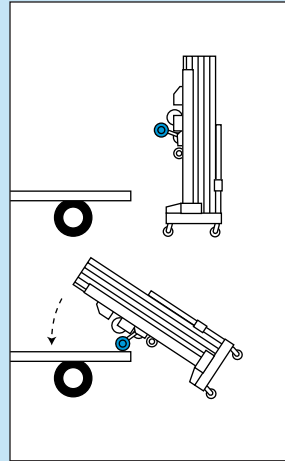

This unit can be loaded onto a flat bed vehicle with the minimum of effort.

Wheel the unit to the rear of the vehicle, **tilt the unit back until the dolly wheels are resting on the bed.** With help, **lift the base of the unit and slide it onto the vehicle.**

If necessary, the front legs and forks can be removed for transit to make the unit more compact.

Note that the hold down bar MUST be engaged or the forks will slide back and forth, causing damage to the unit. Ensure the unit is securely tied to the vehicle before driving off.



...any comments?

If you have any suggestions to enable us to improve the information within this guide please fax your comments or write to the Product Manager at the address below

Fax: 020 687 5001

©HSS Hire Service Group Plc 1998 No. LS15/01
Group Office: 25 Willow Lane, Mitcham, Surrey CR4 4TS

Web Site: <http://www.hss.co.uk>

Operating & Safety Guide LS15

LS15/01

HSS Lift & Shift

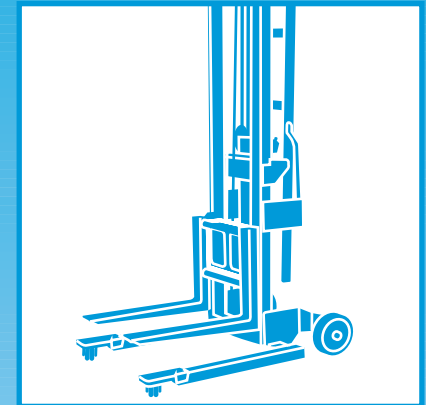

Genie Lifts

A Compact manually operated lift.



Code 70102/5

GENERAL SAFETY



For advice on the safety and suitability of this equipment contact your local HSS Lift & Shift Depot.

There is a serious risk of personal injury if you do not follow all instructions laid down in this guide.

This equipment is designed to be used by an able bodied, competent adult who has read and understood these instructions. Anyone with either a temporary or permanent disability, should seek expert advice before using it.

Keep children, animals and bystanders away from the work area. Cordon off a NO GO area using cones and either barriers or tape.

 **Never use this equipment if you are ill, feeling tired, or under the influence of alcohol or drugs.**

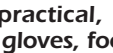
    **Wear practical, protective clothing, gloves, footwear and a protective hard hat.** Avoid loose garments and jewellery that could catch in moving parts, tie back long hair.

 **Use this equipment for vertical lifts only and use on a level area able to take the combined weight of the load and the equipment.**

 **Ensure the load is balanced and stable and that personnel stand clear of the raised load.**

Make sure you know how to operate this equipment safely and are aware of its limitations before you use it.

It is both the hirers and the operators responsibility to perform a risk assessment before using this equipment. You are also responsible for the safety of any one in the work area.

Make sure that anyone in the immediate work area is warned of what you are doing. Never allow anyone under a raised load or in a position where they are at risk if the load shifts.

Never use the lift near overhead power lines or similar hazards. Never use the lift in windy conditions.

Be aware of the raised load when close to ceilings or other overhead obstructions.

This equipment MUST NOT be used to carry personnel or loose loads.

Never exceed the lift's safe working load for the item being lifted. Refer to the 'SWL' chart in this guide.

Do not use this equipment to raise items which are longer or wider than the fork. Ensure the load has a flat base or if not, is attached to a suitable pallet.

Check the condition of the equipment before use. If it shows signs of damage or excessive wear, return it to your local HSS Lift & Shift Depot.

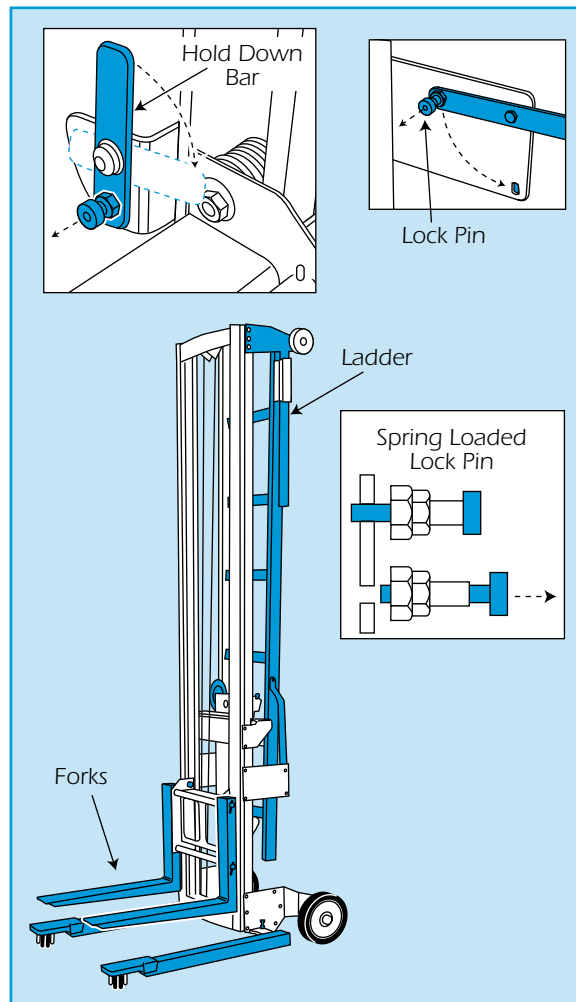

GETTING STARTED

Wheel the unit to the area where it is required.

Most adjustable or removable parts on this equipment are held in position with spring loaded lock pins. These pins **MUST** always be fully engaged when in use. To release the pins simply pull out and hold until the part being removed or adjusted has been moved clear, then simply release.

Park the unit on firm, level ground and ensure that it will be deployed onto a firm footing.

DO NOT use on slopes, soft ground or where there is a risk of subsiding.

Disengage the hold down bar, simply disengage the lock pin and move the hook clear of the fork assembly until it clicks in the clear position.

All that remains is to remove the winch handle and replace the correct way round (see illustration).

Attaching Winch Handle

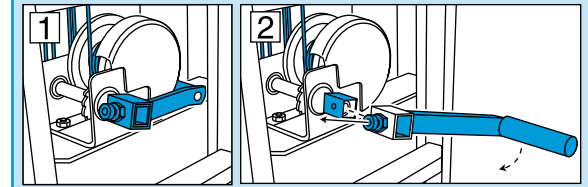

The lift should now be ready to use. However do double-check that all the retaining pins are correctly replaced and all legs (and stabilisers are correctly deployed) before the lift is used.

BASIC TECHNIQUES

The load MUST be secured to the forks, DO NOT presume that the load will 'keep itself in place'.

Use ratchet strapping, DO NOT use ropes or elastic 'bungie' straps.

The load should be evenly distributed over the fork area **and must not exceed the units safe working load (SWL) as stated in the SWL Chart.**

HSS Code	SWL	Maximum Lift
70102	181Kg	2.5M
70105	159Kg	3.65M

To raise the load turn the winch clockwise and to lower turn anti-clockwise. The winch is designed to operate 'silently' and will automatically engage a brake mechanism as necessary.

There is no need to make any alterations for lifting or lowering, simply turn the winch in the direction you require.

Always **position yourself so you can control the Lift while staying clear of the suspended load.**

Take your time and don't overdo it. You are more likely to have an accident if you are tired or rushing.

The larger model is fitted with an aluminium ladder which can be unclipped and swung out to gain access to the rear of the raised load. This ladder should only be used for this purpose and not as a convenient general purpose access ladder.

To deploy the ladder pull the 2 lock pins simultaneously and, taking care not to trap your fingers and keeping your feet clear, swing the ladder down.