

## Fork Extensions

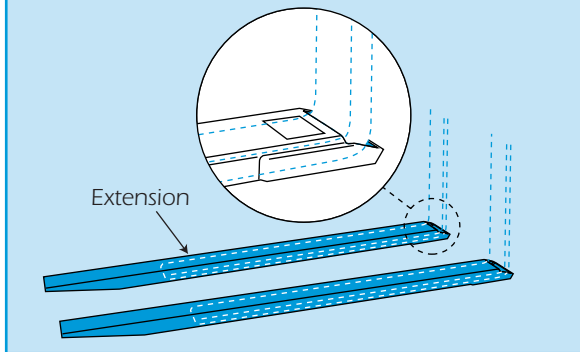

### Fork extensions...

Used to increase the surface area of the forks when the load is light but bulky.

The extensions when fitted, must not extend by more than 50% of the original fork's length.

Care must be taken with regard to extending the load's forward centre of gravity, as the forklift may become unstable (front heavy).

The loads centre of gravity must not extend beyond half the extensions length.

## Dozer/Pusher Blade

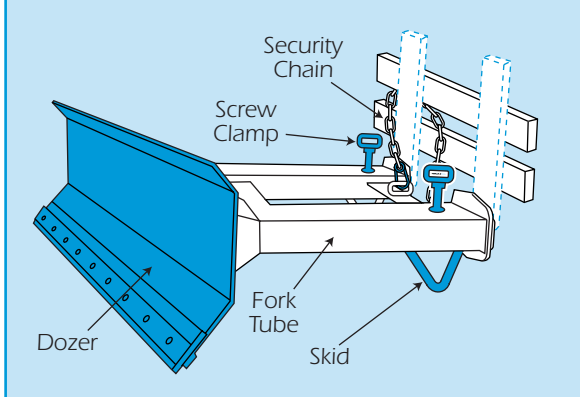

### Dozer / Pusher Blade...

For clearing rubbish, waste and granular material.

When lowered, the back skids on the fork tubes keep the Dozer at the correct angle. It must only be used for pushing material, not for pulling or lifting.

Whatever you are using...

Be aware of the weight of items being loaded and stop when the SWL of the forklift or attachment is reached.

Once loaded drive the forklift to its destination, taking all necessary precautions on the way.

Make sure you take into consideration the centre of gravity of the load when moving the forklift forward,

backward or sideways. **Never allow anyone under or in front of an attachment**, loaded or unloaded.

**DO NOT use on slopes, soft ground or where there is a risk of the forklift subsiding.**

Always **position yourself so you can control the attachment and load while staying clear of the suspended load.**

**Take your time and don't overdo it.** You are more likely to have an accident if you are tired or rushing.

## EQUIPMENT CARE

**Never push the equipment beyond its design limits.** If it will not do what you want with reasonable ease and speed, assume you have the wrong attachment for the job. Contact your local HSS Lift & Shift Depot for advice.

**Keep the equipment clean**, you will find this less of a chore if you clean it regularly, rather than wait until the end of the hire period.

When not in use, **store the equipment somewhere clean, dry and safe** from thieves and unauthorised users.

## FINISHING OFF

Gently **lower the attachment to the ground and where necessary, close and lock extensions**, remove the security chain and then remove it from the forks. **Give the attachment a final clean up ready for return**, to your local HSS Lift & Shift Depot.



## ...any comments?

If you have any suggestions to enable us to improve the information within this guide please fax your comments or write to the Product Manager at the address below

**Fax: 0181-687 5001**

©HSS Hire Service Group Plc 1999 No. LS25/01

Group Office: 25 Willow Lane, Mitcham, Surrey CR4 4TS

Web Site: <http://www.hss-liftandshift.co.uk>

## Operating & Safety Guide LS25

# HSS Lift & Shift

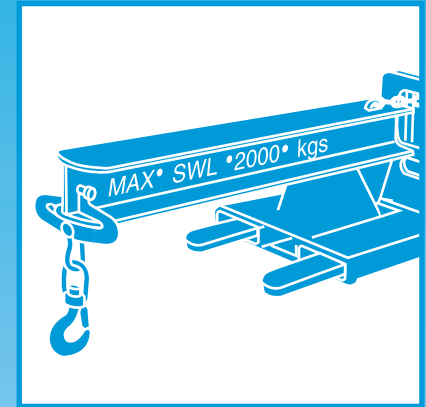

# Forklift Attachments

A wide selection of forklift attachments, ideal for lifting and clearing applications.



Code 70201/3/5/8/9/10/11/14

## GENERAL SAFETY





For advice on the safety and suitability of this equipment contact your local HSS Lift & Shift Depot.

There is a serious risk of personal injury if you do not follow all instructions laid down in this guide.

This equipment is designed to be used by an able bodied, competent adult who has read and understood these instructions. Anyone with either a temporary or permanent disability should seek expert advice before using it.

Keep children, animals and bystanders away from the work area. Cordon off a NO GO area using cones and either barriers or tape, available for hire from your local HSS Lift & Shift Depot.

 Never use this equipment if you are ill, feeling tired, or under the influence of alcohol or drugs.

    Wear practical, protective clothing, gloves, footwear and a protective hard hat. Avoid loose garments and jewellery that could catch in moving parts, tie back long hair.

 Use this equipment for vertical lifts only and secure to the forklift with the chain and karabiner hook supplied.

 Ensure the load is balanced, stable and that personnel stand clear of the raised load.

Make sure you know how to operate this equipment safely and are aware of its limitations before you use it.

It is both the hirer's and the operator's responsibility to perform a risk assessment before using this equipment. You are also responsible for the safety of any person in the work area.

Make sure that anyone in the immediate work area is warned of what you are doing.

Never use the forklift near overhead power lines or similar hazards.

Be aware of the raised load when close to ceilings or other overhead obstructions.

## Warning

This equipment **MUST NOT** be used to carry personnel.

Never exceed the equipment's safe working load as stated on the data plate.

Ensure the load has a flat base or if not, is either attached to a suitable pallet or specially designed attachment.

Ensure the total weight of the attachment plus load does not exceed 50% of the forklift's safe working load (SWL).

Never use an attachment unless the forks are fully engaged and the security chain is correctly fitted. Keep your hands, feet and head clear of the attachment at all times.

Check the condition of the equipment before use. If it shows signs of damage or excessive wear, return it to your local HSS Lift & Shift Depot.

## GETTING STARTED

Ensure too, that the operator is both qualified and insured to drive the forklift.

Set and lock the forks at the correct width for the attachment, then slide the forks fully into the attachment's fork tubes/loops.

Either attach the security chain around the upright of the nearest fork or fully tighten the screw clamps (see respective illustration).

The attachment is now ready to be used.

## ATTACHMENTS

If you are unsure about the fitting or safe use of any of these attachments, contact your local HSS Lift & Shift Depot for advice.

The following attachments are fitted to the existing forks.

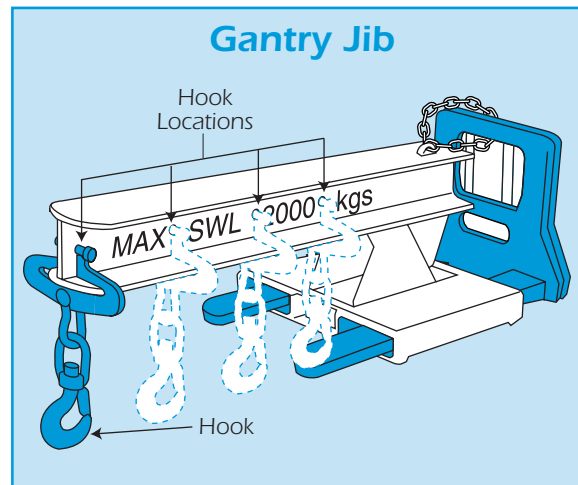

Forklift Gantry Jibs...

These adapters are slotted onto the existing forks and secured in place using the chain and karibina hook supplied (see illustration).

The attachment's capacity to lift decreases as the load hook is extended and all manufacturers SWL warnings must be complied with.

Fixed Jibs allow for only minor adjustment, usually by moving the location of the hook.

When the hook's position is altered, the locating bolt **MUST** be refitted securely before use.

With adjustable Jibs, release the top retaining pin, slide the inner jib out or in as required. Ensure the retaining pin is relocated correctly before use.

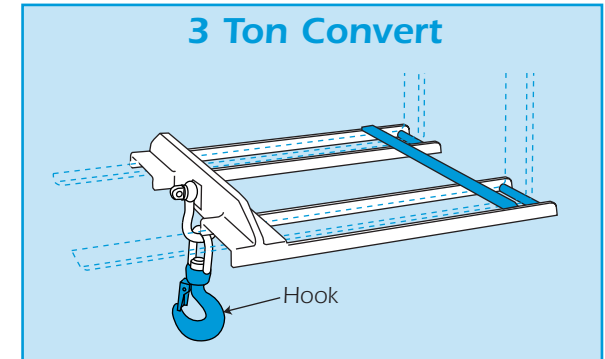

3 Ton Convert...

This attachment simply sits over the existing forks. It allows for lifting by hook and can be used for lifting loads of up to 3 ton, where the forks lift's SWL permits

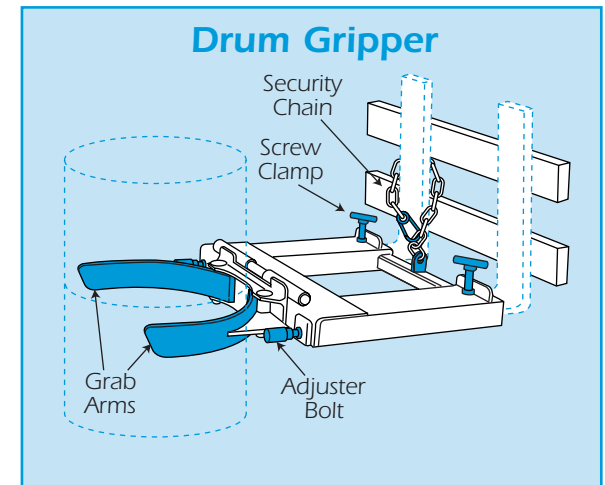

Drum Grippers...

This attachment can lift ether 55-gallon ribbed metal drums or 'L' ring plastic drums.

Once fitted set the grab arms to suit the size of barrel by turning the adjuster bolts as necessary.

The Drum Gripper is automatic, simply move the attachment to the drum until the drum makes contact with the back of the grab arms, this action will cause the arms to close in on the drum.

Once gripped, raise the drum without moving back. To release the drum, lower to the ground and simply reverse the forklift.

It is advisable to practice this operation on an empty barrel until you are confident at carrying out this operation.