

HSS Hire Shops

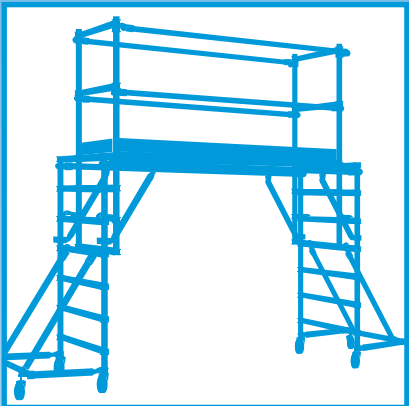

Span Access Platform

Easy to assemble, easy to carry 1.9m access platform that can span over obstacles up to 1.5m high.



Code 80880

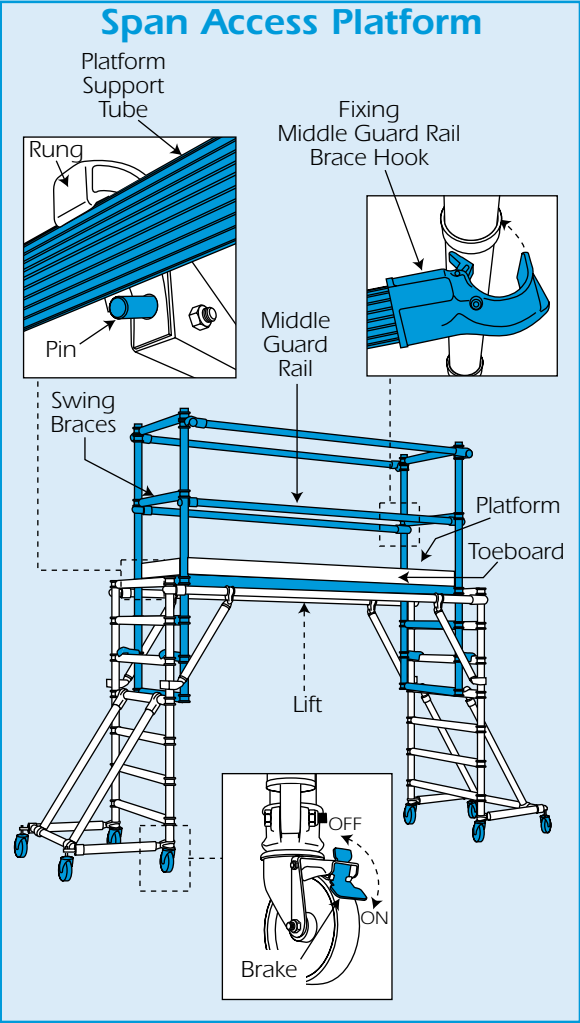

ALWAYS brake ALL wheel castors before climbing onto the platform.
ONLY enter and exit the platform by climbing on at either end.
NEVER climb onto the unit without having the clearance brace and clearance brace diagonals fitted.
NEVER move the unit with people on the platform.
USE on firm, flat level surfaces only.
DO NOT exceed the safe working load – 225kg.

EQUIPMENT CARE

Never push the equipment beyond its design limits. If it will not do what you want with reasonable ease and speed, assume you have the wrong tool for the job. Contact your local HSS Hire Shop for advice.

Keep the equipment clean – you will find this less of a chore if you clean it regularly, rather than wait until the end of the hire period.

Immediately wash off any spills of paint, or other fluids that could mark or stain the equipment.
 When not in use, **store the equipment somewhere clean, dry and safe** from thieves.

FINISHING OFF

Disassemble the Platform by reversing the instructions in GETTING STARTED, collect all the components together and **give the unit a final clean up ready for return, to your local HSS Hire Shop.**

Component	Quantity
End Frame (1.8m)	2
Platform (2.5m)	1
Toeboard set (2.5m)	1
Guard rail frame (1.0m)	2
Guard Rail Brace (2.2m)	4



...any comments?
 If you have any suggestions to enable us to improve the information within this guide please fax your comments or write to the Product Manager at the address below
Fax: 020 8687 5001

©HSS Hire Service Group Plc 2002 No. 438/01
 Group Office: 25 Willow Lane, Mitcham, Surrey CR4 4TS
 Web Site: <http://www.hss.com>

GENERAL SAFETY

For advice on the safety and suitability of this equipment contact your local HSS Hire Shop.

There is a **serious risk of personal injury** if you do not follow all instructions laid down in this guide.

The hirer has a responsibility to ensure that all necessary risk assessments have been completed prior to the use of this equipment.

This equipment should only be used by an operator who has been deemed competent to do so by his/her employer.

This equipment should be used by an able bodied, competent adult who has read and understood these instructions. Anyone with either a temporary or permanent disability, should seek expert advice before using it.

Keep children, animals and bystanders away from the work area. Cordon off a NO GO area using cones and either barriers or tape, available for hire from your local HSS Hire Shop.

 Never use this equipment if you are ill, feeling tired, or under the influence of alcohol or drugs.

 Wear practical, protective clothing, gloves, footwear and a hard hat.

Avoid loose garments and jewellery that could catch in moving parts, tie back long hair.

Ensure the work area is well lit and ventilated, if in doubt, ask about lighting and ventilation equipment at your local HSS Hire Shop.

Do not work near flammable gases or liquids, petrol or paint thinner fumes for example. Keep combustible materials at a safe distance – at least 5m.

Never use this equipment near overhead power lines or similar hazards.

Make sure that anyone in the immediate work area is warned of what you are doing.

Check the condition of the equipment before use. If it shows signs of damage or excessive wear, return it to your local HSS Hire Shop.

GETTING STARTED

It is essential to familiarise yourself with the equipment before starting.

The HSS Span Access Platform must be assembled before use; it is recommended that two people assemble the platform.

To assemble the platform, take all the components to the work area.

Lay the two end supports on the ground, raise the end support frame so that it is at a 90-degree angle to the end frame tubes. Lifting the end support base will also lift the end support braces.

The end support braces have two brace hooks, when the end support base is at 90 degrees to the

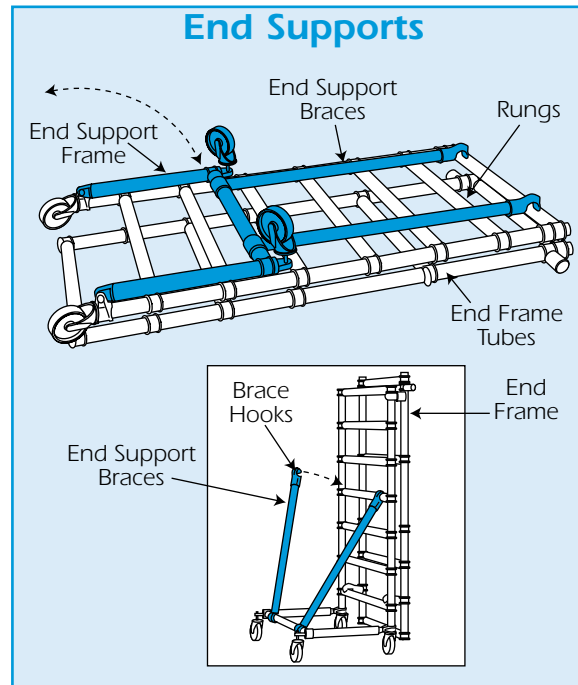

end support frame, these will align with one of the rungs. Affix the hooks to this rung.

When the brace hooks have been fixed to the rungs, raise the end frame so that it is vertical and stands on all of its wheels.

Repeat the procedure for the other end support and place them parallel facing each other.

Fix the clearance brace to the tops of the outer most set of vertical tubes on the end frame using the brace hooks. Loosen the coupler holding the clearance brace diagonals back and secure this to the vertical of the end frame tube.

Fix the brace hooks to the pivot points on the end frames.

Raise the end frames to the required working height, to do this release the four hooks attached to the end frames and lift the assembly up two rungs. Refit the hooks to the rungs, repeat the procedure at the other end support, then repeat at the other end moving the assembly up in stages to the desired height.

The end support frame forms the guard rail for the platform and allows you to install the guard rail before you enter the platform, once the safety rails are at the required height.

Install the platform ensuring the hooks are secured over the rungs. The platform hook is equipped with a spring-loaded pin, which self-locates under the rung.

Climb onto the platform, opening the swing brace(s) on the end frame to gain access. Install the middle guard rails, from the inside, using the brace hooks to the

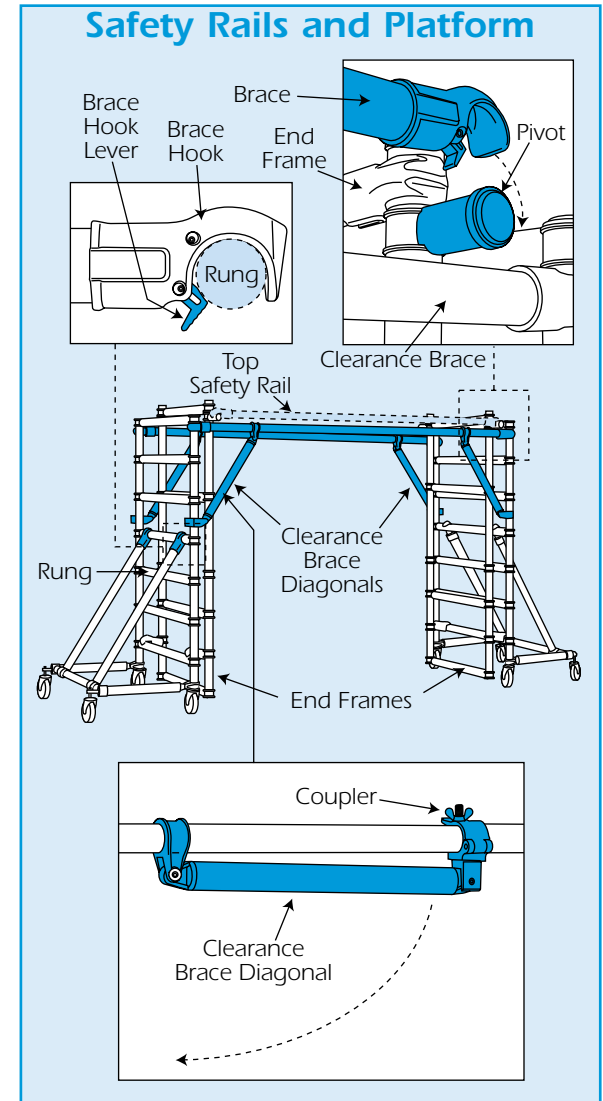

end frame verticals at either side. Open and install one-piece toeboard set so that it fits snugly around the platform.

Push the Access Platform to the correct location and brake all the wheels using the integral wheel brakes, (see illustration).

The Access Platform is ready to use.

The platform may be located on any rung to give the optimum working height. The end frame assembly should be re-located to rest on the same rung as the platform and provide the correct guard heights.

DO NOT climb onto the platform until it has been fully assembled.

ENSURE all brace hooks are secure.