

If using **lightweight stagings**, these will **span up to 7.3m** without intermediate support with **both ends extending a minimum of 600mm** past each trestle.

Have an **able-bodied assistant to help lift the staging or boards into position.**

Ensure both boards and staging rest securely on their trestles.

Keep the equipment clean, you will find it less of a chore if you clean it regularly rather than at the end of the hire period.

When not in use, store the equipment somewhere clean, dry and safe from thieves.

FINISHING OFF

Dismantle the assembly, simply reverse the erection procedure, then give everything a final clean, ready for return to your local HSS Hire Shop.

NOTE: If transporting boards or stagings on a roof rack, tie down securely and ensure they do not protrude more than 1m beyond the front or rear of your vehicle.



...any comments?

If you have any suggestions to enable us to improve the information within this guide please fax your comments or write to the Product Manager at the address below

Fax: 020 8687 5001

©HSS Hire Service Group 2004 No. 781/02

Group Office: 25 Willow Lane, Mitcham, Surrey CR4 4TS

Web Site: <http://www.hss.co.uk>

Operating & Safety Guide 781

781/02

HSS Hire Shops

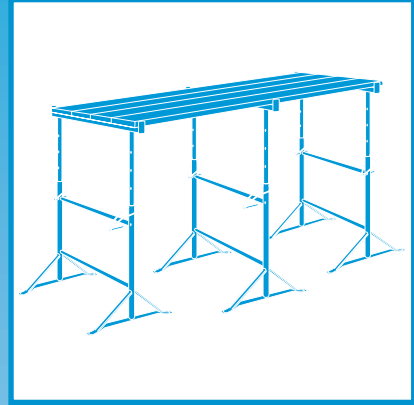

Steel Trestles & Scaffold Boards

Steel trestles can be used with scaffold boards or lightweight staging, to provide a work platform. Ideal for when brickwork or plastering is to be carried out.



Code 83501/2/3-83608/13

GENERAL SAFETY

New Health and Safety regulations, introduced in early 1997, now require that a work platform of 2m and above must have a minimum platform width of 600mm and be fitted with twin bar guard rails with toe boards on each side.

Single scaffold boards supplied by HSS must NOT be used at 2m and above, as their width is only 225mm. However, they may be used at 2m and above if a minimum of three are laid side by side (giving a platform width of 675mm approx.), and any guard rail and toe board will have to be fabricated from tube and clip type scaffolding.

For advice on the safety and suitability of this equipment contact your local HSS Hire Shop.

Keep children, animals and bystanders away from the work area.

Never use this equipment if you are ill, feeling tired, or under the influence of alcohol or drugs.

This equipment should only be used by a competent person who has read and understood these instructions.



Wear sensible clothing and stout, comfortable footwear offering good grip. If necessary, wear gloves and goggles.



A hard hat must be worn by everyone in the work area.

Don't attempt to use access equipment unless you feel comfortable working at heights.

Never use access equipment unless there is someone within ear-shot to summon help in the event of an accident.

Warning!

Do not stack materials or step onto any unsupported end of a board or staging.

Never carry equipment while climbing unless you can do so leaving your hands free, by carrying the equipment in a shoulder bag. Climb first, then haul the equipment up after you on a rope.

Be aware and check for overhead or wall mounted power cables and similar hazards, when using access equipment.

Check the equipment's condition before use. If it shows signs of damage or excessive wear, return it to your local HSS Hire Shop immediately.

Never use this equipment in very windy or blustery conditions.

Never lean too far to one side to reach.

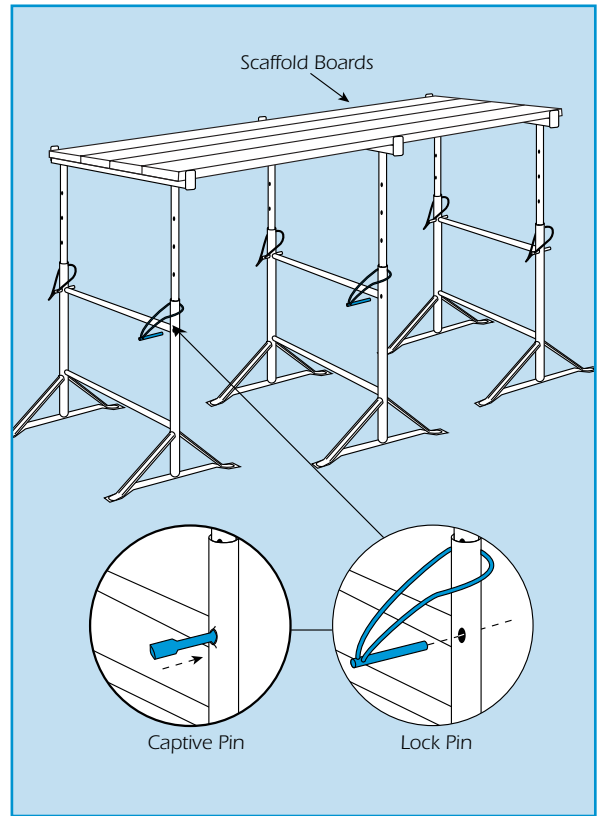

Never do anything that involves applying a lot of side force. The trestle could topple over.

The maximum safe working load of a scaffold board is 150 KG evenly spaced. The total weight of the user and tools must not exceed this.

When moving to a new site, carry the equipment with care.

Never use steps, boxes etc. to gain extra height.

GETTING STARTED

Always set up the equipment on a firm, level, non-slip surface. On soft ground, stand the equipment on boards to stop it sinking in.

Place each trestle at 1.5m intervals which allows the scaffold boards to be adequately supported. Then **open each up to the height required, ensure the locking pins are properly located.**

Now place the scaffold boards on to the trestles, they should be supported at least every 1.5m. To obtain a safe working platform, **use at least four scaffold boards laid side by side.** Ensure an overlap of between 50mm and 150mm over the two end trestles.