

Set the telescopic supports to the desired height, locking them with the pins provided. Start with a medium extension and adjust during cooking.

Fit the turning handle or electric motor as required.

When you are ready to roast, set the spit assembly on the fire tray.

EQUIPMENT CARE

Handle the equipment with care, avoid dropping or knocking it and don't force components when setting up or packing the barbecue away.

Keep the equipment clean. You will find this less of a chore if you clean up as soon as the barbecue is cool.

When not in use, store the barbecue somewhere clean, dry and safe from thieves.

FINISHING OFF

When you have finished cooking, either leave the fire to burn itself out, or pour a bucket of cold water over the coals.

Now, leave the barbecue to cool before, cleaning out the fire tray and washing both the spit and grill top.

Finally, unlock the leg braces and fold up the legs ready to return, to your local HSS Hire Shop.



...any comments?

If you have any suggestions to enable us to improve the information within this guide please fax your comments or write to the Product Manager at the address below

Fax: 0181-687 5001

Operating & Safety Guide 788

HSS Hire Shops

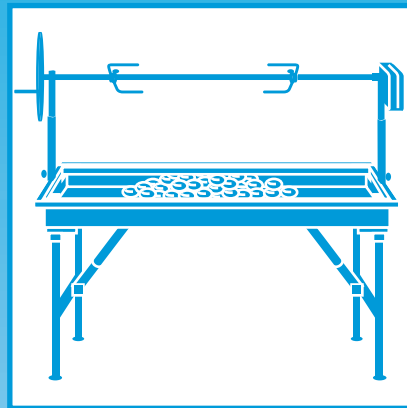

Large Barbecue Grill & Roasting Spit

A traditional Charcoal Barbecue complete with grill rack and optional roasting spit.

©HSS Hire Service Group Plc 1998 No. 788/01

Group Office: 25 Willow Lane, Mitcham, Surrey CR4 4TS

Web Site: <http://www.hss.co.uk>

Code 90115 / 90119

GENERAL SAFETY

For advice on the safety and suitability of this equipment **contact your local HSS Hire Shop.**

There is a serious risk of personal injury if you do not follow all instructions laid down in this guide.

This equipment should be used by an able bodied, competent adult who has read and understood these instructions. Anyone with either a temporary or permanent disability, should seek expert advice before using it.

Keep children, animals and bystanders away from the Barbecue and cooking area.



Never use this equipment if you are ill, feeling tired, or under the influence of drugs.

Never use the barbecue indoors or in a poorly ventilated environment.

Don't use the barbecue in strong, gusty winds. The flame could get out of control.

Keep a bucket of water handy to treat burns and to douse the charcoal fire if it gets out of control. To prevent flare-ups, use a water spray to damp down fire.

Wear suitable, hygienic clothing while cooking and serving, an apron or overall and hat. Tie back long hair and avoid loose garments that could catch fire.

Remember that **barbecues get very hot.** Allow plenty of time for the fire tray, grill top and spit **to cool before touching** or cleaning them.

Wear thick, insulated gloves to handle the grill rack and spit during cooking.

Take extra care when basting or cooking fatty meats. Juices and fat will spit as they drip onto the fire and could cause it to flare up.

Never attempt to move the barbecues while it is alight. First douse the fire, leave everything to cool, then remove the grill and/or spit.

Always check the condition of the equipment before use. If it shows signs of damage or excessive wear, return it to your local HSS Hire Shop.

COSHH information sheets are available from your local HSS Hire Shop.

GETTING STARTED

Set the barbecue up on a firm, level site where people won't bump into it, away from anything that will burn – buildings, fences and trees etc.

Make sure that the site offers plenty of cooking space and easy access for serving.

Hinge out each leg and lock the brace hinge with the sliding sleeve.

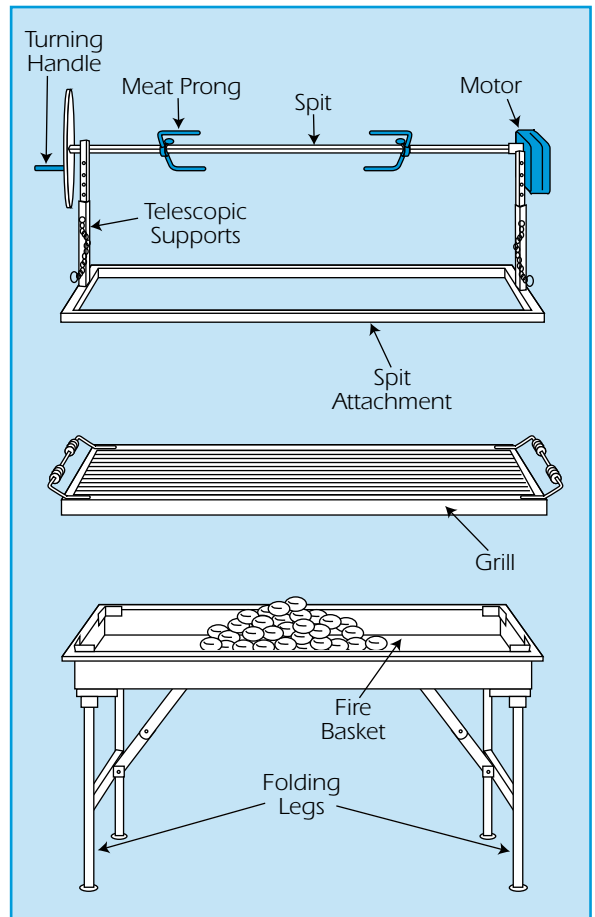

Lighting Charcoal

Pile some broken up firelighters and charcoal fragments in the centre of the fire tray. Place about 2kg of charcoal briquettes on top and light the firelighters with a spill. Once the fire is established (it takes an hour or two) add enough briquettes to cover the fire tray's floor.

Finally, once the charcoal is glowing red/grey and almost stopped smoking, rake it out to form an even bed and start cooking.

Light the fire and wait for it to become established (see box) before fitting the desired cooking top.

If grilling, lay the grill top over the fire tray.

If spit roasting, do not fit the grill top, slide the first prong onto the spit, then the meat, securing this with the second prong before mounting the spit on to its frame.